

CHAPTER 171. SCHOOL BUSES AND SCHOOL VEHICLES

Subchap.	Sec.
A. GENERAL PROVISIONS	171.1
B. SCHOOL BUS CHASSIS STANDARDS	171.11
C. SCHOOL BUS BODY STANDARDS	171.41
D. ADDITIONAL STANDARDS FOR SPECIALLY EQUIPPED SCHOOL BUSES AND SCHOOL VEHICLES	171.91
E. SCHOOL VEHICLE STANDARDS	171.121
F. MASS TRANSIT PUPIL TRANSPORTATION BUS STANDARDS	171.131
G. OPERATION STANDARDS FOR VEHICLES SUBJECT TO THIS CHAPTER	171.141

Authority

The provisions of this Chapter 171 issued under the Vehicle Code, 75 Pa.C.S. §§ 4551, 4552 and 4553, unless otherwise noted.

Source

The provisions of this Chapter 171 adopted August 12, 1977, effective August 13, 1977, 7 Pa.B. 2255; rescinded and replaced in its entirety August 19, 1983, effective August 20, 1983, 13 Pa.B. 2561. Immediately preceding text appears at serial pages (56751), (59741) to (59742), (56754) to (56765), (59745) to (59746), (56768) to (56769) and (82381).

Cross References

This chapter cited in 22 Pa. Code § 51.91 (relating to school buses); 22 Pa. Code § 51.93 (relating to school vehicles); 67 Pa. Code § 71.2 (relating to definitions); and 67 Pa. Code § 173.3 (relating to display requirements).

Subchapter A. GENERAL PROVISIONS

Sec.	
171.1.	Applicability.
171.2.	Definitions.
171.3.	Modification.

§ 171.1. Applicability.

(a) *Scope.* This chapter applies to equipment and safety requirements for school buses as provided for in 75 Pa.C.S. § 4552 (relating to general requirements for school buses) and for other vehicles transporting school children as provided for in 75 Pa.C.S. § 4553 (relating to general requirements for other vehicles transporting school children).

(b) *Exemptions.* School buses manufactured or converted prior to September 14, 1996, must comply with the regulations in effect at the time they were manufactured or converted, except that Subchapter G (relating to operation standards for vehicles subject to this chapter) applies to vehicles subject to this chapter regardless of the date of manufacture or conversion.

(c) *FMVSS*. Vehicles manufactured as school buses are required to be in compliance with FMVSS as established by the National Highway Traffic Safety Administration (NHTSA) at 49 CFR 571 (relating to Federal Motor Vehicle Safety Standards).

(d) *Federal Motor Carrier Safety Regulations*. Vehicles manufactured as school buses and operating in interstate commerce are required to be in compliance with Federal Motor Carrier Safety Regulations as established by the Federal Highway Administration (FHWA) at 49 CFR Parts 393 and 396 (relating to parts and accessories necessary for safe operation; and inspection, repair and maintenance). See Appendix A.

Authority

The provisions of this § 171.1 amended under the Vehicle Code, 75 Pa.C.S. §§ 4103, 4551—4553 and 6103.

Source

The provisions of this § 171.1 adopted August 12, 1977, effective August 13, 1977, 7 Pa.B. 2255; amended August 4, 1978, effective July 1, 1979, 8 Pa.B. 2194; amended July 20, 1979, effective July 21, 1979, 9 Pa.B. 2401; amended March 27, 1981, effective March 28, 1981, 11 Pa.B. 1100; amended August 19, 1983, effective August 20, 1983, 13 Pa.B. 2561; readopted December 4, 1987, effective December 5, 1987, 17 Pa.B. 5052; amended September 13, 1996, effective September 14, 1996, 26 Pa.B. 4411; amended May 20, 2005, effective May 21, 2005, 35 Pa.B. 3039. Immediately preceding text appears at serial pages (291597) to (291598).

§ 171.2. Definitions.

The following words and terms, when used in this chapter, have the following meanings, unless the context clearly indicates otherwise:

Bus—A motor vehicle designed to transport 16 or more passengers, including the driver; or a motor vehicle, other than a taxicab or limousine, designed to transport not more than 15 passengers, including the driver, and used for the transportation of persons for compensation. The term does not include a vehicle used in a ridesharing arrangement, as defined in the act of December 14, 1982 (P. L. 1211, No. 279) (55 P. S. §§ 695.1—695.9), which provides for ridesharing arrangements and provides that certain laws are inapplicable to ridesharing arrangements, or a school bus.

Converted school bus—A vehicle not originally manufactured to be a school bus.

Convex mirror—A mirror having a curved reflective surface whose shape is the same as that of the exterior surface of a section of a sphere.

Department—The Department of Transportation of the Commonwealth.

Designated seating position—Under 49 CFR 571.3 (relating to definitions), a plain view location capable of accommodating a person at least as large as a 5th percentile adult female, if the overall seat configuration and vehicle design is of a type that the position is likely to be used as a seating position while the

vehicle is in motion, except for auxiliary seating accommodations such as temporary or folding jump seats. A bench or split bench seat in a passenger car, truck or multipurpose passenger vehicle with a GVWR less than 10,000 pounds, having greater than 50 inches of hip room (measured in accordance with SAE Standard J1100(a)—See Appendix A) may not have less than three designated seating positions, unless the seat design or vehicle design is of a type that the center position cannot be used for seating.

FMVSS—Federal Motor Vehicle Safety Standards published in the *Code of Federal Regulations*.

Forward control—A configuration in which more than half of the engine length is rearward of the foremost point of the windshield base and the steering wheel hub is in the forward quarter of the vehicle length.

GVWR—*Gross vehicle weight rating*—The value specified on the Federal weight certification label by the manufacturer as the loaded weight of a single vehicle.

Insignia—Any identification statement, symbol, figure, logo or distinguishing sign, name or mark.

Mass transit pupil transportation bus—A bus, other than a school bus, that is operated by an urban mass transportation system and used exclusively for the transportation of children to and from school and school-related activities, even if used for other transportation purposes at other times.

Multifunction school activity bus—A school bus used to transport students on field trips, athletic trips or other curricular or extracurricular activities, but not used for to-and-from school transportation.

Pupil Transportation Section—The Pupil Transportation Section of the Bureau of Driver Licensing of the Department.

SAE—The Society of Automotive Engineers.

School—An institution for the education or training of children, including but not limited to kindergartens, rehabilitation centers, day care centers, Head Start centers, group day care homes, family day care homes and summer camps.

School bus—A motor vehicle designed to carry 11 passengers or more, including the driver, and used for the transportation of preprimary, primary or secondary school students to or from public, private or parochial schools or events related to these schools or school-related activities. The types of school buses are as follows:

- (i) *Type A school bus*. A school bus converted from or having a body constructed upon a van-type truck or front-section vehicle chassis, with a left side driver's door and the entrance doors behind the front wheels. This definition includes two classifications: Type A1, with a Gross Vehicle Weight Rating (GVWR) less than or equal to 10,000 pounds; and Type A2, with a GVWR greater than 10,000 pounds.

(ii) *Type B school bus.* A school bus constructed utilizing a stripped chassis, with the entrance door behind the front wheels. This definition includes two classifications: Type B1, with a GVWR less than or equal to 10,000 pounds; and Type B2, with a GVWR greater than 10,000 pounds.

(iii) *Type C school bus.* A school bus constructed utilizing a chassis with a hood and front fender assembly without a left side driver's door and with the entrance door behind the front wheels.

(iv) *Type D school bus.* A school bus constructed utilizing a stripped chassis with the entrance door ahead of the front wheels.

School vehicle—A motor vehicle, except a motorcycle, designed for carrying no more than ten passengers, including the driver, and used for the transportation of preprimary, primary or secondary school students while registered by or under contract to a school district or private or parochial school. The term includes vehicles having chartered, group and party rights under the Pennsylvania Public Utility Commission and used for the transportation of school children.

Specially equipped school bus—A school bus used to transport children which, in addition to meeting the requirements for school buses as described in this chapter, contains special equipment as required in Subchapter D (relating to additional standards for specially equipped school buses and school vehicles).

Stop signal arm—A device that can be extended outward from the side of the school bus to provide a signal to other motorists not to pass because the bus has stopped to load and discharge passengers.

Type 2 seat belt assembly—A combination of pelvic and upper torso restraints.

Unit magnification mirror—A plane or flat mirror with a reflective surface through which the angular height and width of the image of an object is equal to the angular height and width of the object when viewed directly at the same distance except for flaws that do not exceed normal manufacturing tolerances.

Upper torso restraint—A portion of a seatbelt assembly intended to restrain movement of the chest and shoulder regions.

Authority

The provisions of this § 171.2 amended under Vehicle Code, 75 Pa.C.S. §§ 4103, 4551—4553 and 6103.

Source

The provisions of this § 171.2 adopted August 12, 1977, effective August 13, 1977, 7 Pa.B. 2255; amended August 4, 1978, effective July 1, 1979, 8 Pa.B. 2194; amended July 20, 1979, effective July 21, 1979, 9 Pa.B. 2401; amended August 19, 1983, effective August 20, 1983, 13 Pa.B. 2561; corrected September 3, 1983, effective August 20, 1983, 13 Pa.B. 2707; readopted December 4, 1987, effective December 5, 1987, 17 Pa.B. 5052; amended July 7, 1989, effective July 8, 1989, 19 Pa.B. 2957; amended September 13, 1996, effective September 14, 1996, 26 Pa.B. 4411; amended May 20, 2005, effective May 21, 2005, 35 Pa.B. 3039. Immediately preceding text appears at serial pages (219598) to (219601).

§ 171.3. Modification.

A secondary manufacturer which modifies the original school bus shall guarantee the performance of workmanship and materials resulting from the modification.

Source

The provisions of this § 171.3 adopted August 19, 1983, effective August 20, 1983, 13 Pa.B. 2561; readopted December 4, 1987, effective December 5, 1987, 17 Pa.B. 5052. Immediately preceding text appears at serial page (83731).

Cross References

This section cited in 67 Pa. Code § 171.23 (relating to frame).

Subchapter B. SCHOOL BUS CHASSIS STANDARDS

Sec.	
171.11.	Applicability.
171.12.	Air cleaner.
171.13.	Axles.
171.14.	Brakes.
171.15.	Bumper, front.
171.16.	Certification.
171.17.	Clutch.
171.18.	Color.
171.19.	Driveshaft protection.
171.20.	Electrical system.
171.21.	Exhaust system.
171.22.	Fenders, front on Type C school buses.
171.23.	Frame.
171.24.	Fuel system.
171.25.	Governor.
171.26.	Heating system.
171.27.	Horn.
171.28.	Instruments and instrument panel.
171.29.	Oil filter.
171.30.	Openings.
171.31.	Passenger's load.
171.32.	Power and gradeability.
171.33.	Shock absorbers.
171.34.	Springs.
171.35.	Steering gear.
171.36.	Tires and rims.
171.37.	Transmission.
171.38.	Undercoating.

Cross References

This subchapter cited in 67 Pa. Code § 171.91 (relating to general requirement).

§ 171.11. Applicability.

This subchapter applies to all school buses, unless a particular requirement is by its terms applicable only to one or more types of school buses.

Source

The provisions of this § 171.11 adopted August 12, 1977, effective August 13, 1977, 7 Pa.B. 2255; amended August 4, 1978, effective July 1, 1979, 8 Pa.B. 2194; amended August 19, 1983, effective August 20, 1983, 13 Pa.B. 2561; readopted December 4, 1987, effective December 5, 1987, 17 Pa.B. 5052. Immediately preceding text appears at serial page (83732).

§ 171.12. Air cleaner.

The engine intake air cleaner system shall be installed in accordance with the chassis manufacturer's specifications. Engine intake cleaner system components shall comply with the engine manufacturer's specifications.

Authority

The provisions of this § 171.12 amended under the Vehicle Code, 75 Pa.C.S. §§ 4103, 4551—4553 and 6103.

Source

The provisions of this § 171.12 adopted August 12, 1977, effective August 13, 1977, 7 Pa.B. 2255; amended August 4, 1978, effective July 1, 1979, 8 Pa.B. 2194; amended August 19, 1983, effective August 20, 1983, 13 Pa.B. 2561; readopted December 4, 1987, effective December 5, 1987, 17 Pa.B. 5052; amended September 13, 1996, effective September 14, 1996, 26 Pa.B. 4411. Immediately preceding text appears at serial page (122777).

§ 171.13. Axles.

The front and rear axles, including suspension assemblies, shall have a gross axle weight rating at ground at least equal to that portion of the load as would be imposed by the chassis manufacturer's maximum gross vehicle weight rating.

Source

The provisions of this § 171.13 adopted August 12, 1977, effective August 13, 1977, 7 Pa.B. 2255; amended August 4, 1978, effective July 1, 1979, 8 Pa.B. 2194; amended August 19, 1983, effective August 20, 1983, 13 Pa.B. 2561; readopted December 4, 1987, effective December 5, 1987, 17 Pa.B. 5052. Immediately preceding text appears at serial page (83732).

§ 171.14. Brakes.**(a) General rule.**

(1) Unless otherwise provided for by this section, a school bus must be equipped with a chassis brake system which conforms with the provisions of FMVSS No. 105, No. 106 and No. 121, as applicable.

(2) The antilock brake system (ABS), provided in accordance with FMVSS No. 105 or No. 121, shall provide wheel speed sensors for each front wheel and for each wheel on at least one rear axle. The system shall provide antilock braking performance for each wheel equipped with sensors.

(3) Brake systems shall be designed to permit visual inspection of brake lining wear without removal of any chassis components.

(4) The brake lines, booster-assist lines and control cables shall be protected from excessive heat, vibration and corrosion and installed in a manner which prevents chafing.

(5) The parking brake system for either air or hydraulic service brake systems may be of a power assisted design. The power parking brake actuator shall be a push-pull device located on the instrument panel within seated reach of a 5th percentile female driver. As an option, the parking brake may be set by placing the automatic transmission shift control mechanism in the “park” position.

(6) The power-operated parking brake system may be interlocked to the engine key switch so that once the parking brake has been set and the ignition switch turned to the “off” position, the parking brake cannot be released until the key switch is turned back to the “on” position.

(b) *Hydraulic brakes.* A bus using a hydraulic-assist brake shall be equipped with audible and visible warning signals that provide a continuous warning to the driver of a loss of fluid flow from the primary source and of a failure of the back-up pump system.

(c) *Air brakes.* A bus equipped with air brakes shall conform to the following:

(1) The air pressure supply system shall include a desiccant-type air dryer installed according to the manufacturers’ recommendations. The air pressure storage tank system may incorporate an automatic drain valve.

(2) The dashboard instrument panel of a bus equipped with an air brake system shall include an air pressure gauge of a type allowing the driver to comply with CDL pretrip inspection requirements.

(3) An air brake shall have both a visible and audible warning device whenever the air pressure falls below the level where warnings are required under FMVSS No. 121.

Authority

The provisions of this § 171.14 amended under the Vehicle Code, 75 Pa.C.S. §§ 4103, 4551—4553 and 6103.

Source

The provisions of this § 171.14 adopted August 12, 1977, effective August 13, 1977, 7 Pa.B. 2255; amended August 4, 1978, effective July 1, 1979, 8 Pa.B. 2194; amended August 19, 1983, effective August 20, 1983, 13 Pa.B. 2561; readopted December 4, 1987, effective December 5, 1987, 17 Pa.B. 5052; amended September 13, 1996, effective September 14, 1996, 26 Pa.B. 4411; amended May 20, 2005, effective May 21, 2005, 35 Pa.B. 3039. Immediately preceding text appears at serial pages (219602) to (219604).

§ 171.15. Bumper, front.

(a) *General rule.* Every school bus shall be equipped with a front bumper of a type, and installed as, recommended by the chassis manufacturer or a front bumper of an equivalent material that complies with 49 CFR 581 (relating to bumper standard). See Appendix A.

(b) *Extension.* The front bumper shall extend beyond the forwardmost part of the body, grille, hood and fenders and shall extend to the outer edges of the fenders at the bumper top line.

(c) *Strength.* The front bumper, except breakaway bumper ends, shall be of sufficient strength to permit pushing a vehicle of equal gross vehicle weight without permanent distortion to the bumper, chassis or body.

(d) *Exception.* Type D school bus front bumper shall be of a type, and installed as, recommended by the body manufacturer or a front bumper of an equivalent material that complies with 49 CFR 581. See Appendix A.

(e) *Energy absorbing.* If equipped with an energy-absorbing front bumper, the bumper manufacturer, upon request, shall furnish certification to the Department verifying the bumper complies with 49 CFR 581. See Appendix A.

Authority

The provisions of this § 171.15 amended under the Vehicle Code, 75 Pa.C.S. §§ 4103, 4551—4553 and 6103.

Source

The provisions of this § 171.15 adopted August 12, 1977, effective August 13, 1977, 7 Pa.B. 2255; amended August 4, 1978, effective July 1, 1978, 8 Pa.B. 2194; amended August 19, 1983, effective August 20, 1983, 13 Pa.B. 2561; readopted December 4, 1987, effective December 5, 1987, 17 Pa.B. 5052; amended September 13, 1996, effective September 14, 1996, 26 Pa.B. 4411. Immediately preceding text appears at serial page (122779).

§ 171.16. Certification.

Every school bus chassis manufacturer shall, upon request, certify to the Department that items not covered by the certification issued under the requirements of the National Traffic and Motor Vehicle Safety Act of 1966 (15 U.S.C.A. §§ 1381—1481), meet the requirements of this chapter. Persons or entities making additions or alterations to a school bus chassis after the time of manufacture, upon request, shall furnish certification to the Department that items, additions or alterations meet the requirements of the National Traffic and Motor Safety Act and the requirements of this chapter.

Authority

The provisions of this § 171.16 amended under the Vehicle Code, 75 Pa.C.S. §§ 4103, 4551—4553 and 6103.

Source

The provisions of this § 171.16 adopted August 4, 1978, effective July 1, 1979, 8 Pa.B. 2194; amended August 19, 1983, effective August 20, 1983, 13 Pa.B. 2561; readopted December 4, 1987, effective December 5, 1987, 17 Pa.B. 5052; amended September 13, 1996, effective September 14, 1996, 26 Pa.B. 4411. Immediately preceding text appears at serial page (122779).

§ 171.17. Clutch.

The clutch shall have a clutch torque capacity equal to or greater than the engine torque output.

Source

The provisions of this § 171.17 adopted August 4, 1978, effective July 1, 1979, 8 Pa.B. 2194; amended August 19, 1983, effective August 20, 1983, 13 Pa.B. 2561; readopted December 4, 1987, effective December 5, 1987, 17 Pa.B. 5052. Immediately preceding text appears at serial page (83734).

§ 171.18. Color.

(a) *General rule.* A school bus chassis, including wheels and bumpers, shall be black. A school bus hood, cowl and fender shall be National School Bus Yellow. See Appendix B.

(b) *Exceptions.* Exceptions to subsection (a) are as follows:

(1) Wheel rims shall be of a trim used by the rim manufacturer.

(2) School bus hoods may be nonreflective National School Bus Yellow—See Appendix A—or lusterless black matching National Institute of Standards and Technology (NIST) Federal Standard No. 595a, Color 37038. See Appendix A.

(3) The service door frame may be black.

(4) The mirror brackets and other body accessories may be stainless steel with a satin finish.

(c) *Multifunction school activity bus.* The color requirements in this section do not apply to multifunction school activity buses.

Authority

The provisions of this § 171.18 amended under the Vehicle Code, 75 Pa.C.S. §§ 4103, 4551—4553 and 6103.

Source

The provisions of this § 171.18 adopted August 19, 1983, effective August 20, 1983, 13 Pa.B. 2561; readopted December 4, 1987, effective December 5, 1987, 17 Pa.B. 5052; amended September 13, 1996, effective September 14, 1996, 26 Pa.B. 4411; amended May 20, 2005, effective May 21, 2005, 35 Pa.B. 3039. Immediately preceding text appears at serial pages (219605) to (219606).

Cross References

This section cited in 67 Pa. Code § 171.59 (relating to lamps and signals).

§ 171.19. Driveshaft protection.

The driveshaft shall be protected by at least one metal guard or bracket around the circumference of the driveshaft to prevent the driveshaft whipping through the floor or dropping to the ground if there is a failure of the driveshaft or any of its component parts.

Authority

The provisions of this § 171.19 amended under the Vehicle Code, 75 Pa.C.S. §§ 4103, 4551—4553 and 6103.

Source

The provisions of this § 171.19 adopted August 19, 1983, effective August 20, 1983, 13 Pa.B. 2561; readopted December 4, 1987, effective December 5, 1987, 17 Pa.B. 5052; amended September 13, 1996, effective September 14, 1996, 26 Pa.B. 4411. Immediately preceding text appears at serial page (122781).

§ 171.20. Electrical system.

(a) *Battery*. The requirements for the battery are as follows:

(1) The battery shall have a minimum cold cranking capacity rating equal to the cranking current required for 30 seconds at 0° F (-17.8° C) and a minimum reserve capacity rating of 120 minutes at 25 amp. Higher capacities may be required dependent upon optional equipment and local environmental conditions.

(2) Batteries in Type B, C and D school buses shall be mounted on a sliding tray.

(b) *Generator or alternator*. Requirements for generators and alternators are as follows:

(1) Every Type A and B school bus up to 15,000 pounds GVWR shall have a minimum 60 ampere per hour alternator.

(2) Every Type B school bus over 15,000 pounds GVWR and every Type C and D school bus shall be equipped with an alternator meeting SAE Standard J180b—See Appendix A—with a minimum output rating of 100 amperes, capable of producing a minimum of 50% of its maximum rated output at the engine manufacturer's recommended idle speed.

(3) Every school bus equipped with an electrical power lift shall have a minimum 100 ampere per hour alternator.

(4) A direct drive generator or alternator is permissible in lieu of belt drive. Belt drive shall be capable of handling the rated capacity of the generator or alternator with no detrimental effect on other driven components.

(5) Refer to *SBMI Design Objectives Booklet*. See Appendix A—for required generator or alternator capacity.

(c) *Wiring*. Requirements for wiring are as follows: Wiring shall conform to current applicable SAE Standards. Wiring and circuits shall be of a standard color

and number coding and each chassis shall have a wiring diagram and circuit that coincides with the wiring and circuitry of the chassis.

Authority

The provisions of this § 171.20 amended under the Vehicle Code, 75 Pa.C.S. §§ 4103, 4551—4553 and 6103.

Source

The provisions of this § 171.20 adopted August 19, 1983, effective August 20, 1983, 13 Pa.B. 2561; readopted December 4, 1987, effective December 5, 1987, 17 Pa.B. 5052; amended September 13, 1996, effective September 14, 1996, 26 Pa.B. 4411; amended May 20, 2005, effective May 21, 2005, 35 Pa.B. 3039. Immediately preceding text appears at serial pages (219606) and (301813).

Cross References

This section cited in 67 Pa. Code § 171.43 (relating to battery).

§ 171.21. Exhaust system.

(a) *General rule.* The exhaust pipe, muffler and tailpipe shall be outside the body compartment and securely attached to the chassis with clamps and hangers of a type and installed as recommended by the chassis manufacturer.

(b) *Tailpipe.* The tailpipe shall be constructed of a corrosion-resistant tubing material at least equal in strength and durability to 16 gauge steel tubing.

(c) *Tailpipe extension.* The exhaust system of a school bus powered by a gasoline engine shall discharge to the atmosphere at or within 6 inches forward of the rearmost part of the school bus.

(d) *Tailpipe extension for school buses using fuels other than gasoline.* The exhaust system for a school bus using fuels other than gasoline shall discharge to the atmosphere either at or within 15 inches forward of the rearmost part of the vehicle; or to the rear of all doors or windows designed to be opened, except windows designed to be opened solely as emergency exits.

(e) *Insulation.* The exhaust system on a gasoline powered chassis shall be properly insulated from fuel tank connections by a securely attached metal shield at any point where it is 12 inches or less from the tank or tank connections.

(f) *Muffler.* The muffler shall be constructed of corrosion resistant material.

(g) *Discharge lines and outlets.* The discharge lines and outlets on school buses equipped with compressed or liquefied gas fuel systems shall be installed in accordance with Chapter 175 (relating to vehicle equipment and inspection).

(h) *Exhaust system hangers.* Exhaust systems may be equipped with hangers that permit required movement due to expansion and contraction caused by heat of the exhaust and relative motion between the engine and chassis of a vehicle.

(i) *Exhaust system and discharge location.* Exhaust systems are not permitted to discharge to the atmosphere at a location immediately below the fuel tank or the fuel tank filler pipe. Exhaust systems shall also extend and discharge completely to the outside edge of the vehicle body.

(j) *Exception.* This section does not apply to auxiliary fuel-fired heating systems.

Authority

The provisions of this § 171.21 amended under the Vehicle Code, 75 Pa.C.S. §§ 4103, 4551—4553 and 6103.

Source

The provisions of this § 171.21 adopted August 4, 1978, effective July 1, 1979, 8 Pa.B. 2194; amended August 31, 1979, effective September 1, 1979, 9 Pa.B. 2954; amended August 19, 1983, effective August 20, 1983, 13 Pa.B. 2561; readopted December 4, 1987, effective December 5, 1987, 17 Pa.B. 5052; amended September 13, 1996, effective September 14, 1996, 26 Pa.B. 4411; amended November 26, 2003, effective November 29, 2003, 33 Pa.B. 5817; amended May 20, 2005, effective May 21, 2005, 35 Pa.B. 3039. Immediately preceding text appears at serial page (301814).

§ 171.22. Fenders, front on Type C school buses.

(a) *Spread.* The total spread of outer edges of front fenders on Type C school buses, measured at the fender line, shall exceed the total spread of the front tires when the front wheels are in the straight ahead position.

(b) *Bracing.* Front fenders shall be properly braced and free from any body attachments other than mirrors specified in § 171.61 (relating to mirrors).

Authority

The provisions of this § 171.22 amended under the Vehicle Code, 75 Pa.C.S. §§ 4103, 4551—4553 and 6103.

Source

The provisions of this § 171.22 adopted August 4, 1978, effective July 1, 1979, 8 Pa.B. 2194; amended August 19, 1983, effective August 20, 1983, 13 Pa. B. 2561; readopted December 4, 1987, effective December 5, 1987, 17 Pa.B. 5052; amended September 13, 1996, effective September 14, 1996, 26 Pa.B. 4411. Immediately preceding text appears at serial pages (122782) to (122783).

§ 171.23. Frame.

(a) *General.* The frame or equivalent of every school bus shall be of such design and strength characteristics as to correspond at least to standard practice for trucks of the same general load characteristics which are used for highway service.

(b) *Side rails.* There may be no holes in the top or bottom flanges of the frame side rail except as provided in the original chassis frame.

(c) *Length.* Frame lengths shall be in accordance with *SBMI Design Objectives Booklet*. See Appendix A.

(d) *Modification.* A frame modification may not be for the purpose of extending the wheelbase. A secondary manufacturer, person or entity that modifies the original frame shall comply with § 171.3 (relating to modification) and 49 CFR 568.8 (relating to requirements for persons who alter certified vehicles).

Authority

The provisions of this § 171.23 amended under the Vehicle Code, 75 Pa.C.S. §§ 4103, 4551—4553 and 6103.

Source

The provisions of this § 171.23 adopted August 4, 1978, effective July 1, 1979, 8 Pa.B. 2194; amended August 19, 1983, effective August 20, 1983, 13 Pa.B. 2561; readopted December 4, 1987, effective December 5, 1987, 17 Pa.B. 5052; amended September 13, 1996, effective September 14, 1996, 26 Pa.B. 4411. Immediately preceding text appears at serial page (122783).

§ 171.24. Fuel system.

(a) *Fuel tanks.* Fuel tanks shall be as provided by the chassis manufacturer. They shall be filled at and vented to the outside of the body, at a location so that accidental fuel spillage will not drip or drain on any part of the exhaust system.

(b) *Location of system.* No portion of the fuel system which is located to the rear of the engine compartment, except the filler tube, may extend above the top of the chassis frame rail. Fuel lines shall be mounted to obtain maximum possible protection from the chassis frame.

(c) *Fuel filter.* A fuel filter with replaceable element shall be installed between the fuel tank and the engine.

(d) *Installation.* The fuel tank installation shall be in accordance with *SBMI Design Objectives Booklet*. See Appendix A.

(e) *Compressed and liquified gas.* School buses equipped with compressed or liquified gas fuel systems shall comply with Chapter 175 (relating to vehicle equipment and inspection).

(f) *Auxiliary fuel tank.* If a school bus is equipped with an auxiliary fuel tank, the fuel tank shall be in accordance with *SBMI Design Objectives Booklet*. See Appendix A.

Authority

The provisions of this § 171.24 amended under the Vehicle Code, 75 Pa.C.S. §§ 4103, 4551—4553 and 6103.

Source

The provisions of this § 171.24 adopted August 4, 1978, effective July 1, 1979, 8 Pa.B. 2194; amended August 19, 1983, effective August 20, 1983, 13 Pa.B. 2561; readopted December 4, 1987, effective December 5, 1987, 17 Pa.B. 5052; amended September 13, 1996, effective September 14, 1996, 26 Pa.B. 4411. Immediately preceding text appears at serial pages (122783) to (122784).

§ 171.25. Governor.

When the engine is remotely located from the driver, a governor shall be installed to limit the engine speed to the maximum revolutions per minute recommended by the engine manufacturer, or a tachometer shall be installed so the engine speed may be known to the driver.

Source

The provisions of this § 171.25 adopted August 19, 1983, effective August 20, 1983, 13 Pa.B. 2561; readopted December 4, 1987, effective December 5, 1987, 17 Pa.B. 5052. Immediately preceding text appears at serial page (83738).

§ 171.26. Heating system.

The chassis engine shall be equipped with plugged openings to supply hot water for the school bus heating system. The openings shall be suitable for attaching 3/4 inch pipe thread/hose connectors. The engine shall be capable of supplying water having a temperature of at least 170° F at a flow rate of 50 pounds/per minute at the return end of 30 feet of 1 inch inside diameter automotive hot water heater hose. See SBMI Standard No. 001 in Appendix A.

Authority

The provisions of this § 171.26 amended under the Vehicle Code, 75 Pa.C.S. §§ 4103, 4551—4553 and 6103.

Source

The provisions of this § 171.26 adopted August 19, 1983, effective August 20, 1983, 13 Pa.B. 2561; readopted December 4, 1987, effective December 5, 1987, 17 Pa.B. 5052; amended September 13, 1996, effective September 14, 1996, 26 Pa.B. 4411. Immediately preceding text appears at serial page (122784).

§ 171.27. Horn.

School buses shall be equipped with at least one horn of standard make, which is audible under normal conditions for distances of not less than 200 feet.

Authority

The provisions of this § 171.27 amended under the Vehicle Code, 75 Pa.C.S. §§ 4103, 4551—4553 and 6103.

Source

The provisions of this § 171.27 adopted August 19, 1983, effective August 20, 1983, 13 Pa.B. 2561; readopted December 4, 1987, effective December 5, 1987, 17 Pa.B. 5052; amended September 13, 1996, effective September 14, 1996, 26 Pa.B. 4411. Immediately preceding text appears at serial page (122784).

§ 171.28. Instruments and instrument panel.

(a) *Required instruments.* Lights in lieu of gauges are not acceptable, except as noted. Every school bus chassis shall be equipped with the following instruments and gauges:

- (1) Speedometer.
- (2) Odometer, in working order, which will give accrued mileage—to seven digits—including tenths of miles.

(3) Voltmeter. An ammeter with graduated charge and discharge, with ammeter and wiring compatible with generating capacities is permitted in lieu of a voltmeter.

(4) Oil-pressure gauge.

(5) Water temperature gauge.

(6) Fuel gauge.

(7) Upper beam headlight indicator.

(8) Brake indicator gauge—vacuum or air. Light indicator in lieu of gauge is permitted on a school bus equipped with a hydraulic-over-hydraulic brake system.

(9) Turn signal indicator.

(10) Glow-plug indicator light, where appropriate.

(b) *Visibility*. Instruments and gauges shall be mounted on the instrument panel so that each is clearly visible to the driver while in normal seated position in accordance with *SBMI Design Objectives Booklet*. See Appendix A.

(c) *Lamps*. Every instrument panel shall have lamps of sufficient candle-power to illuminate instruments, gauges and, if a school bus is equipped with an automatic transmission, the shift selector indicator.

Authority

The provisions of this § 171.28 amended under the Vehicle Code, 75 Pa.C.S. §§ 4103, 4551—4553 and 6103.

Source

The provisions of this § 171.28 adopted August 19, 1983, effective August 20, 1983, 13 Pa.B. 2561; readopted December 4, 1987, effective December 5, 1987, 17 Pa.B. 5052; amended September 13, 1996, effective September 14, 1996, 26 Pa.B. 4411. Immediately preceding text appears at serial pages (122784) to (122785).

§ 171.29. Oil filter.

The oil filter shall be of replaceable element or cartridge type and shall be connected by flexible oil lines if it is not of built-in or engine mounted design. The oil filter shall have a capacity of approximately 1 quart.

Source

The provisions of this § 171.29 adopted August 19, 1983, effective August 20, 1983, 13 Pa.B. 2561; readopted December 4, 1987, effective December 5, 1987, 17 Pa.B. 5052. Immediately preceding text appears at serial page (83739).

§ 171.30. Openings.

Openings in the floorboard or firewall between the chassis and the passenger compartment, such as the opening for the gearshift lever and the parking brake lever, shall be sealed.

Source

The provisions of this § 171.30 adopted August 19, 1983, effective August 20, 1983, 13 Pa.B. 2561; readopted December 4, 1987, effective December 5, 1987, 17 Pa.B. 5052. Immediately preceding text appears at serial page (83739).

§ 171.31. Passenger's load.

(a) *Gross vehicle weight.* Actual gross vehicle weight is the vehicle weight, plus the driver's weight, plus the total seated pupil weight.

(1) For purposes of calculation, the driver's weight is 150 pounds.

(2) For purposes of calculation, the pupil weight is 120 pounds per pupil.

(b) *Weight limitations.* The following weight limitations apply:

(1) *Gross weight.* The actual gross weight of the vehicle may not exceed the manufacturer's GVWR for the chassis.

(2) *Axle weights.* A bus may not be operated upon a highway with a weight on an axle in excess of the lesser of the manufacturer's rated axle capacity or 22,400 pounds—20,000 pounds on interstate highways—on a single axle or 18,000 pounds on a dual axle.

(3) *Wheel weights.* A bus may not be operated upon a highway with a weight upon a wheel in excess of 800 pounds for each nominal inch of width of tire on the wheel.

(4) *Gross vehicle weight rating.* A bus may not be operated upon a highway with weight exceeding the value specified on the Federal weight certification label by the manufacturer as the loaded weight of a single vehicle.

Authority

The provisions of this § 171.31 amended under the Vehicle Code, 75 Pa.C.S. §§ 4103, 4551—4553 and 6103.

Source

The provisions of this § 171.31 adopted August 12, 1977, effective August 13, 1977, 7 Pa.B. 2255; amended March 27, 1981, effective March 28, 1981, 11 Pa.B. 1100; amended August 19, 1983, effective August 20, 1983, 13 Pa.B. 2561; readopted December 4, 1987, effective December 5, 1987, 17 Pa.B. 5052; amended September 13, 1996, effective September 14, 1996, 26 Pa.B. 4411. Immediately preceding text appears at serial page (122786).

§ 171.32. Power and gradeability.

Gross vehicle weight may not exceed 185 pounds per net published horsepower of the engine at the manufacturer's recommended maximum number of revolutions per minute.

Source

The provisions of this § 171.32 adopted August 12, 1977, effective August 13, 1977, 7 Pa.B. 2255; amended August 19, 1983, effective August 20, 1983, 13 Pa.B. 2561; readopted December 4, 1987, effective December 5, 1987, 17 Pa.B. 5052. Immediately preceding text appears at serial page (83740).

§ 171.33. Shock absorbers.

Every school bus shall be equipped with front and rear double-acting shock absorbers compatible with the manufacturer's rated axle capacity at each wheel location.

Source

The provisions of this § 171.33 adopted August 12, 1977, effective August 13, 1977, 7 Pa.B. 2255; amended August 19, 1983, effective August 20, 1983, 13 Pa.B. 2561; readopted December 4, 1987, effective December 5, 1987, 17 Pa.B. 5052. Immediately preceding text appears at serial page (83740).

§ 171.34. Springs.

(a) *Capacity.* The capacity of springs or suspension assemblies shall be commensurate with the chassis manufacturer's GVWR.

(b) *Rear springs.* If equipped with rear springs, the springs shall be of a type and installed as recommended by the chassis manufacturer.

Authority

The provisions of this § 171.34 amended under the Vehicle Code, 75 Pa.C.S. §§ 4103, 4551—4553 and 6103.

Source

The provisions of this § 171.34 adopted August 12, 1977, effective August 13, 1977, 7 Pa.B. 2255; amended August 19, 1983, effective August 20, 1983, 13 Pa.B. 2561; readopted December 4, 1987, effective December 5, 1987, 17 Pa.B. 5052; amended September 13, 1996, effective September 14, 1996, 26 Pa.B. 4411. Immediately preceding text appears at serial page (122787).

§ 171.35. Steering gear.

The steering gear system of every school bus shall comply with the following:

(1) The steering gear shall be equal to the original equipment furnished by the chassis manufacturer. If replacement is necessary, it shall be designed to assure safe and accurate performance when the school bus is operated with maximum load and at maximum speed.

(2) The steering mechanism shall be accessible for adjustment.

(3) No changes may be made in the steering apparatus which are not approved by the chassis manufacturer.

(4) There shall be clearance of at least 2 inches between the steering wheel and cowl instrument panel, windshield or other surface.

(5) Power steering is required.

(6) The steering system shall be designed to allow for lubrication of all wear-points.

Authority

The provisions of this § 171.35 amended under the Vehicle Code, 75 Pa.C.S. §§ 4103, 4551—4553 and 6103.

Source

The provisions of this § 171.35 adopted August 19, 1983, effective August 20, 1983, 13 Pa.B. 2561; readopted December 4, 1987, effective December 5, 1987, 17 Pa.B. 5052; amended September 13, 1996, effective September 14, 1996, 26 Pa.B. 4411. Immediately preceding text appears at serial page (122787).

§ 171.36. Tires and rims.

The requirements for the tires and rims of a school bus are as follows:

(1) School buses shall be equipped with tires and rims which conform to the vehicle chassis manufacturer's specifications as to tire size, in that the tires and rims are not smaller than those that have been recommended by the chassis manufacturer. Tires and rims shall meet the requirements of FMVSS Nos. 119 and 120. See Appendix A.

(2) Dual rear tires shall be provided on Type A2, Type B, Type C and Type D school buses.

(3) Tires on the same axle shall be of the same size and type of construction—bias, belted or radial. Type A school bus tires shall be of same size and type of construction on all axles.

(4) If the vehicle is equipped with a spare tire and rim assembly for emergency use, it shall be of the same size as those mounted on the vehicle.

(5) Tube type tires and tubeless equivalent tires shall be provided on dual wheel vehicles.

(6) When tires are replaced, they shall be of a quality equivalent to the original equipment.

(7) Radial type tires at least equivalent in strength and size to the bias construction tire specified may be substituted; however, no mixing of radial type and bias construction type tires may be permitted on the same axle.

(8) Regrooved, recapped or retreaded tires shall comply with the following:

(i) Regrooved, recapped or retreaded tires may not be used on front wheels or on single rear wheels.

(ii) Regrooved tires shall comply with safety standards certified by the tire manufacturer as meeting 49 CFR 569 (relating to regrooved tires)—see Appendix A—and shall be stamped as “Regroovable.”

(iii) Recapped or retreaded tires shall comply with FMVSS No. 117. See Appendix A.

(iv) regroovable tires may be retreaded, recapped or regrooved.

(9) No tire may be used which is in an unsafe condition. Tread depth on tires may at no time be less than 4/32 of an inch on the front and 2/32 of an inch on the rear as measured on two adjacent treads by an acceptable gauge such as the Dill, or its equivalent.

(10) A spare tire, if used, shall be suitably mounted in an accessible location outside the passenger compartment. Types A and B school buses need not comply with this paragraph.

Authority

The provisions of this 171.36 amended under the Vehicle Code, 75 Pa.C.S. §§ 4103, 4551—4553 and 6103.

Source

The provisions of this § 171.36 adopted August 19, 1983, effective August 20, 1983, 13 Pa.B. 2561; readopted December 4, 1987, effective December 5, 1987, 17 Pa.B. 5052; amended September 13, 1996, effective September 14, 1996, 26 Pa.B. 4411; amended May 20, 2005, effective May 21, 2005, 35 Pa.B. 3039. Immediately preceding text appears at serial pages (219614) to (219615).

§ 171.37. Transmission.

(a) *Automatic.* An automatic or semiautomatic transmission shall have at least three forward speeds and one reverse speed.

(b) *Manual.* On manual transmissions, second and higher gears shall be synchronized except when incompatible with engine power. A minimum of three forward speeds and one reverse speed shall be provided.

Authority

The provisions of this § 171.37 amended under the Vehicle Code, 75 Pa.C.S. §§ 4103, 4551—4553 and 6103.

Source

The provisions of this § 171.37 adopted August 19, 1983, effective August 20, 1983, 13 Pa.B. 2561; readopted December 4, 1987, effective December 5, 1987, 17 Pa.B. 5052; amended September 13, 1996, effective September 14, 1996, 26 Pa.B. 4411; amended May 20, 2005, effective May 21, 2005, 35 Pa.B. 3039. Immediately preceding text appears at serial pages (219615) to (219616).

§ 171.38. Undercoating.

The undersides of the front fenders of the chassis—unless fenders are constructed of a noncorrosion material—shall be coated with a rust preventing compound which meets or exceeds, when using the modified test, all performance and qualitative requirements of paragraph 3.4 of Federal Specification TT-C-520b. See Appendix A.

Authority

The provisions of this § 171.38 amended under the Vehicle Code, 75 Pa.C.S. §§ 4103, 4551—4553 and 6103.

Source

The provisions of this § 171.38 adopted August 19, 1983, effective August 20, 1983, 13 Pa.B. 2561; readopted December 4, 1987, effective December 5, 1987, 17 Pa.B. 5052; amended September 13, 1996, effective September 14, 1996, 26 Pa.B. 4411. Immediately preceding text appears at serial page (122789).

Subchapter C. SCHOOL BUS BODY STANDARDS

Sec.	
171.41.	Applicability.
171.42.	Aisle.
171.43.	Battery.
171.44.	Bumper, rear.
171.45.	Certification.
171.46.	Chains.
171.47.	Color.
171.48.	Construction.
171.49.	Defrosters.
171.50.	Doors and emergency exits.
171.51.	Fire extinguisher.
171.52.	First aid.
171.53.	Floor.
171.54.	Heaters.
171.55.	Identification.
171.56.	Inside height.
171.57.	Insulation.
171.58.	Interior.
171.59.	Lamps and signals.
171.60.	Metal treatment.
171.61.	Mirrors.
171.62.	Mounting.
171.63.	Overall length.
171.64.	[Reserved].
171.65.	Pry (wrecking) bar.
171.66.	Rub rails.
171.67.	Traction assist devices.
171.68.	Seat belts.
171.69.	Seats and crash barriers.
171.70.	Steps.
171.71.	Stirrup steps.
171.72.	Storage compartment.
171.73.	Sun shield.
171.74.	[Reserved].
171.74a.	Crossing control arm.
171.75.	Undercoating.
171.76.	Ventilation.
171.77.	Wheelhousing.
171.78.	Windows.
171.79.	Windshield washers.
171.80.	Windshield wipers.
171.81.	Wiring.
171.82.	Backup alarm.
171.83.	Portable emergency warning devices.
171.84.	Additional equipment items.
171.85.	Video equipment.
171.86.	Fire axe.

Cross References

This subchapter cited in 67 Pa. Code § 171.91 (relating to general requirement).

§ 171.41. Applicability.

This subchapter applies to all school buses, unless a particular requirement is by its terms applicable only to one or more types of school buses.

Source

The provisions of this § 171.41 adopted August 4, 1978, effective July 1, 1979, 8 Pa.B. 2194; amended August 19, 1983, effective August 20, 1983, 13 Pa.B. 2561; readopted December 4, 1987, effective December 5, 1987, 17 Pa.B. 5052. Immediately preceding text appears at serial page (83743).

§ 171.42. Aisle.

The requirements for the aisles of a school bus are as follows:

- (1) Minimum clearance of aisles shall be at least 30 centimeters—11 3/4 inches—wide. Aisles shall be unobstructed at all times.
- (2) The seat backs shall be slanted sufficiently to give aisle clearance of 15 inches at tops of seat backs.
- (3) Emergency doors shall be accessible by an aisle at least 30 centimeters—11 3/4 inches—wide.

Authority

The provisions of this § 171.42 amended under the Vehicle Code, 75 Pa.C.S. §§ 4103, 4551—4553 and 6103.

Source

The provisions of this § 171.42 adopted August 4, 1978, effective July 1, 1979, 8 Pa.B. 2194; amended August 19, 1983, effective August 20, 1983, 13 Pa.B. 2561; readopted December 4, 1987, effective December 5, 1987, 17 Pa.B. 5052; amended September 13, 1996, effective September 14, 1996, 26 Pa.B. 4411. Immediately preceding text appears at serial page (122790).

Cross References

This section cited in 67 Pa. Code § 171.92 (relating to aisles); and 67 Pa. Code § 171.144 (relating to seating).

§ 171.43. Battery.

The following rules apply to batteries:

- (1) Original battery shall be as furnished by the chassis manufacturer.
- (2) When the battery is mounted as described in § 171.20(a)(2) (relating to electrical system), it shall be securely attached on a slide-out or swing-out tray in a closed, vented compartment in the body skirt, whereby the battery may be exposed to the outside for convenient servicing. The battery compartment door or cover shall be hinged at the front or top and secured by an adequate and conveniently operated latch or other type fastener.

Source

The provisions of this § 171.43 adopted August 4, 1978, effective July 1, 1979, 8 Pa.B. 2194; amended August 19, 1983, effective August 20, 1983, 13 Pa.B. 2561; readopted December 4, 1987, effective December 5, 1987, 17 Pa.B. 5052. Immediately preceding text appears at serial page (83743).

§ 171.44. Bumper, rear.

(a) *Construction.* The rear bumper shall be:

(1) Of pressed steel channel or an equivalent material which complies with 49 CFR 581 (relating to bumper standard). See Appendix A.

(2) At least 3/16 inch thick.

(3) A minimum of 8 inches wide (high) on Type A school buses.

(4) A minimum of 9 1/2 inches wide (high) on Types B, C and D school buses.

(5) Of sufficient strength to permit pushing by another vehicle without permanent distortion.

(b) *Placement.* The rear bumper shall be wrapped around the back corners of the school bus. It shall extend forward at least 12 inches, measured from the rear-most point of the body at the floor line.

(c) *Attachment.* The rear bumper shall be attached to the chassis frame in such a manner that it may be easily removed, shall be so braced as to develop the full strength of the bumper section from rear or side impact and shall be so attached as to prevent hitching of rides.

(d) *Extension.* The rear bumper shall extend at least 1 inch beyond the rear-most part of the body surface measured at the floor line. Type A school buses are exempt from this subsection.

(e) *Exception.* Bumpers on Type A school buses may be as specified by the manufacturer.

(f) *Energy absorbing.* If a school bus is equipped with an energy absorbing rear bumper, the bumper shall comply with the requirements of this section and 49 CFR 581.

(g) *Tow eyes or hooks.* Tow eyes or hooks, if installed on a school bus, shall be attached to the chassis frame at the front or rear of the school bus and attached so they do not extend beyond the front or rear bumper. Installation shall be in accordance with the chassis manufacturer's specification.

Authority

The provisions of this § 171.44 amended under the Vehicle Code, 75 Pa.C.S. §§ 4103, 4551—4553 and 6103.

Source

The provisions of this § 171.44 adopted August 19, 1983, effective August 20, 1983, 13 Pa.B. 2561; readopted December 4, 1987, effective December 5, 1987, 17 Pa.B. 5052; amended September 13, 1996, effective September 14, 1996, 26 Pa.B. 4411. Immediately preceding text appears at serial page (122791).

§ 171.45. Certification.

School buses manufactured or converted after January 1, 1978, shall bear a certification label from the final stage manufacturer stating that the completed school bus conforms to applicable FMVSS in effect at the time of manufacture. Persons or entities may not alter a previously certified school bus in a way that does not conform to applicable FMVSS in effect at the time of manufacture.

Authority

The provisions of this § 171.45 amended under the Vehicle Code, 75 Pa.C.S. §§ 4103, 4551—4553 and 6103.

Source

The provisions of this § 171.45 adopted August 19, 1983, effective August 20, 1983, 13 Pa.B. 2561; readopted December 4, 1987, effective December 5, 1987, 17 Pa.B. 5052; amended September 13, 1996, effective September 14, 1996, 26 Pa.B. 4411. Immediately preceding text appears at serial pages (122791) to (122792).

§ 171.46. Chains.

Tire chains for drive wheels may be provided.

Source

The provisions of this § 171.46 adopted August 19, 1983, effective August 20, 1983, 13 Pa.B. 2561; readopted December 4, 1987, effective December 5, 1987, 17 Pa.B. 5052. Immediately preceding text appears at serial pages (83744).

§ 171.47. Color.

The requirements for the color of school bus bodies are as follows:

(1) The school bus body shall be painted a uniform National School Bus Yellow. See Appendix B.

(2) The roof of the school bus may be painted white.

(3) The body exterior trim, including the exterior mirrors, may be black. The bumper shall be black.

(4) If a school bus is equipped with reflective material, other than that required under §§ 171.50 and 171.59 (relating to doors and emergency exits; and lamps and signals), the reflective material shall be of automotive engineering grade or better. If additional reflective materials and markings are used, they may be applied as follows:

PLACEMENT OF REFLECTIVE MARKINGS

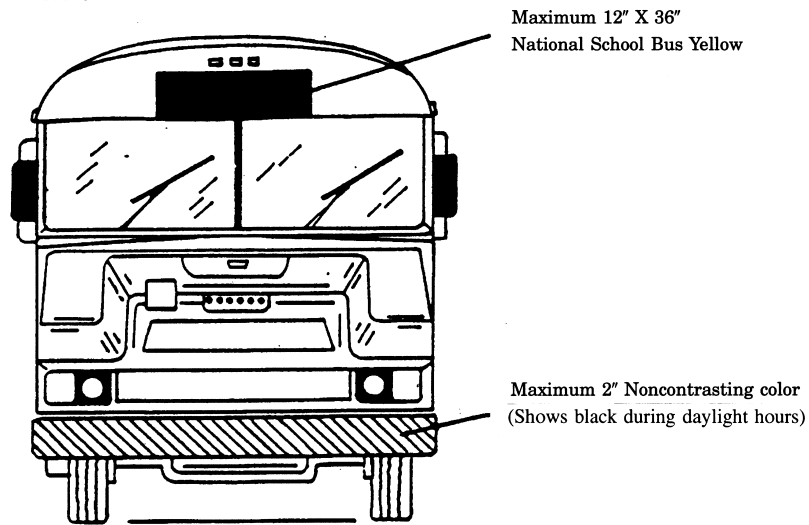

FIGURE 1

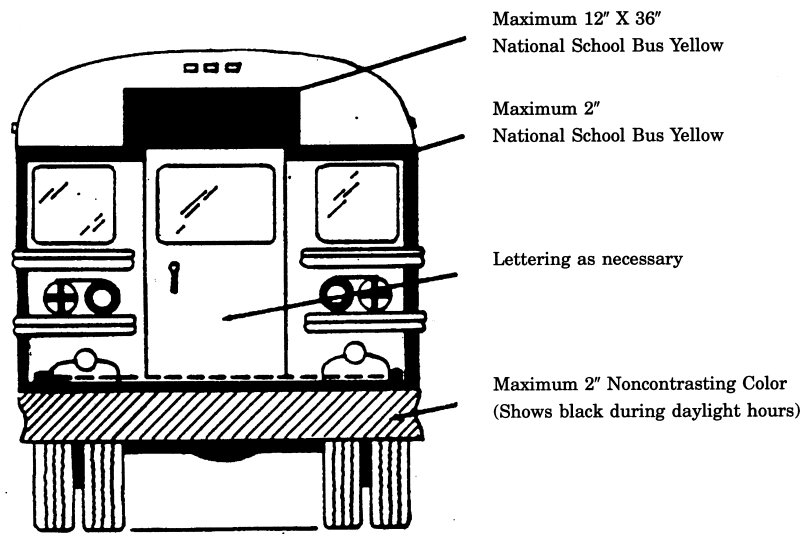

FIGURE 2

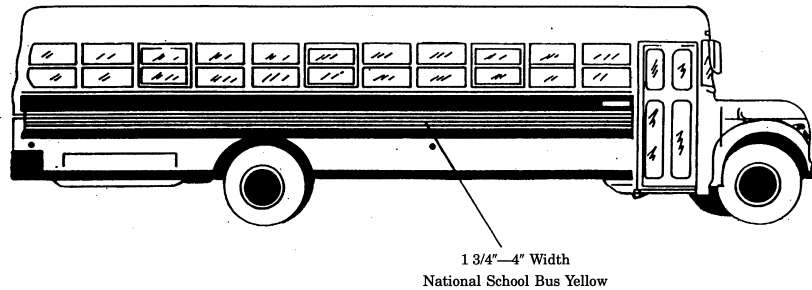

FIGURE 3

- (5) The pilaster (vertical window post) may be black.
- (6) The color requirements in this section do not apply to multifunction school activity buses.

Authority

The provisions of this § 171.47 amended under the Vehicle Code, 75 Pa.C.S. §§ 4103, 4551—4553 and 6103.

Source

The provisions of this § 171.47 adopted August 19, 1983, effective August 20, 1983, 13 Pa.B. 2561; readopted December 4, 1987, effective December 5, 1987, 17 Pa.B. 5052; amended September 13, 1996, effective September 14, 1996, 26 Pa.B. 4411; amended November 26, 2003, effective November 29, 2003, 33 Pa.B. 5817; amended May 20, 2005, effective May 21, 2005, 35 Pa.B. 3039. Immediately preceding text appears at serial pages (301818) to (301820).

§ 171.48. Construction.

Every school bus body shall be constructed of prime commercial quality steel or other metal or material with strength at least equivalent to all steel as certified by the school bus body manufacturer. The body shall be reasonably dustproof and water tight.

Source

The provisions of this § 171.48 adopted August 19, 1983, effective August 20, 1983, 13 Pa.B. 2561; readopted December 4, 1987, effective December 5, 1987, 17 Pa.B. 5052. Immediately preceding text appears at serial page (83744).

§ 171.49. Defrosters.

The requirements for defroster systems are as follows:

- (1) School buses shall be equipped with defrosting and defogging devices to prevent and remove obstructions from the driver's view; for instance, ice, snow or frost on the outside of the windshield or condensation on the inside of the windshield. Defrosting and defogging equipment shall direct a sufficient

flow of heated air onto the windshield, the window to the left of the driver, the glass in the viewing area directly to the right of the driver and the glass in the service door.

(2) The defrosting system shall conform to SAE Standard J 381 and 382. See Appendix A.

(3) The defroster and defogging system shall be capable of furnishing heated outside ambient air, except that part of the system furnishing additional air to the windshield, entrance door and stepwell may be of the recirculating air type.

(4) Auxiliary fans are not to be considered as a defrosting and defogging system.

(5) Portable heater may not be used.

Authority

The provisions of this § 171.49 amended under the Vehicle Code, 75 Pa.C.S. §§ 4103, 4551—4553 and 6103.

Source

The provisions of this § 171.49 adopted August 19, 1987, effective August 20, 1987, 17 Pa.B. 2561; readopted December 4, 1987, effective December 5, 1987, 17 Pa.B. 5052; amended September 13, 1996, effective September 14, 1996, 26 Pa.B. 4411. Immediately preceding text appears at serial pages (122792) to (122793).

§ 171.50. Doors and emergency exits.

(a) *Service doors.* The requirements for service doors are as follows:

(1) The service door shall be under the control of the driver, and designed so as to afford easy release and prevent accidental opening. When a hand lever is used, no part may come together so as to shear or crush fingers.

(2) The service door shall be located on the right side of the school bus opposite the driver and within direct view of the driver.

(3) The service door shall have a minimum horizontal opening of 24 inches and a minimum vertical opening of 68 inches. Type A school bus service doors shall have a minimum opening area of 1,200 square inches.

(4) The service door shall be of the split type, sedan type or jackknife type. Split-type door includes a sectioned door which divides and opens inward or outward. If one section of a split type door opens inward and the other opens outward, the front section shall open outward.

(5) Lower as well as upper windows shall have approved safety glazing. The bottom of the lower window may not be more than 35 inches from the ground when the bus is unloaded. The top of the upper window may not be more than 6 inches from the top of the door. Type A school buses shall have an upper window with an area of at least 350 square inches of approved safety glazing.

(6) Vertical closing edges on split type or folding type entrance doors shall be equipped with flexible material to protect the passengers' fingers. Type A school buses may be equipped with the chassis manufacturer's standard entrance door.

(7) There may be no door to the left of the driver on Type C or D school buses. Type A and B school buses may be equipped with the chassis manufacturer's standard entrance door.

(8) Doors shall be equipped with padding at the top edge of each door opening. The padding shall be at least 3 inches wide and 1 inch thick and extend the full width of the door opening.

(b) *Emergency exits.* Each school bus shall comply with FMVSS No. 217. See Appendix A. The area of square centimeters of the unobstructed opening for emergency exits shall collectively amount to at least 432 multiplied times the number of designated seating positions in the bus. The area of an opening equipped with a wheel chair lift is counted toward meeting additional emergency area requirements only if the lift is designed to be folded or stored so that the area is available for use by persons not needing the lift.

(1) The requirements for emergency exit doors are as follows:

(i) The emergency exit door shall be hinged according to FMVSS No. 217. See Appendix A. Double emergency exit doors shall also be hinged according to FMVSS No. 217. See Appendix A.

(ii) The upper portion of the rear emergency exit door shall have a window equipped with approved safety glazing, the exposed area of which is at least 400 square inches. The lower portion of the rear emergency door on Type B, C and D school buses shall contain a window of approved safety glazing, measuring a minimum of 350 square inches. Type A school buses are exempt from this subparagraph.

(iii) Except as provided in subparagraph (iv), no portion of a seat or a restraining barrier may be installed within the area bounded by the opening of a side emergency exit door, a vertical transverse plane parallel to that plane at a distance of 30 centimeters (11 3/4 inches) forward of that plane, and a longitudinal vertical plane passing through the longitudinal centerline of the bus. See Figure 4.

(iv) A seat bottom may be located within the area described in subparagraph (iii) if the seat bottom pivots and automatically assumes and retains a vertical position when not in use, so that no portion of the seat bottom is within the area described in subparagraph (iii) when the seat bottom is vertical. See Figure 5.

(v) No portion of a seat or restraining barrier—located forward of the area described in subparagraph (iii) and between the door opening and a longitudinal vertical plane passing through the longitudinal centerline of the bus—may extend rearward of a vertical transverse plane tangent to the forwardmost portion of a latch mechanism on the door. See Figures 5 and 6.

(vi) Each emergency exit door of a school bus shall be equipped with a positive door opening device that, after the release mechanism has been operated:

(A) Bears the weight of the door.

(B) Keeps the door from closing past the point at which the door is perpendicular to the side of the bus body, regardless of the body's orientation.

(C) Provides a means for release or override.

(vii) The positive door opening device shall perform the functions specified in subparagraph (vi)(A) and (B) without the need for additional action beyond opening the door past the point at which the door is perpendicular to the side of the bus body.

(viii) Emergency door exits shall be equipped with padding at the top edge of each door opening. The padding shall be at least 3 inches wide and 1 inch thick and extend the full width of the door opening.

(ix) The emergency exit door opening may not be blocked with an obstruction higher than 1/4 inch across the bottom of the emergency exit door opening.

(x) Each school bus emergency exit door shall allow manual release of the door by a single person, from both inside and outside the passenger compartment. The release mechanism shall operate without the use of remote controls or tools, and notwithstanding any failure of the vehicle's power system. When the release mechanism is not in the position that causes an emergency exit door to be closed, and the vehicle's ignition is in the "on" position, a continuous warning sound shall be audible at the driver's seating position.

(xi) Two side emergency exit doors may not be located, in whole or in part, within the same post and roof bow panel space.

(xii) Supplemental security locks installed on emergency doors shall be equipped with an ignition interlock system or an audiovisual alarm located in the driver's compartment. Hasps may not be used.

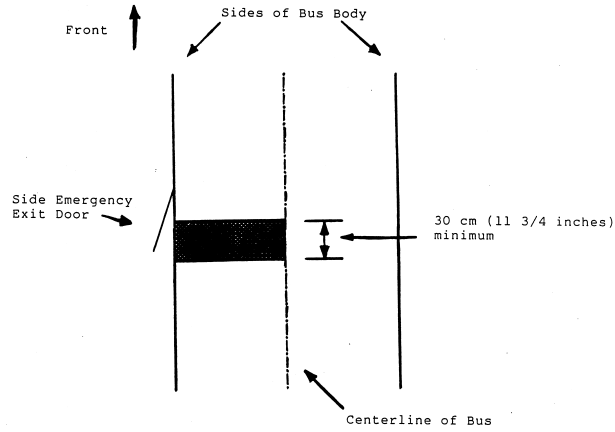

Figure 4 Minimum Side Emergency Exit Clearance Specification (Plan View)

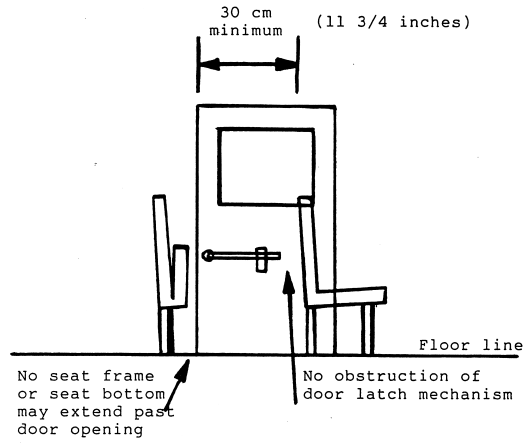

Figure 5 Minimum Side Emergency Exit Flip-Up Seat Clearance Specifications

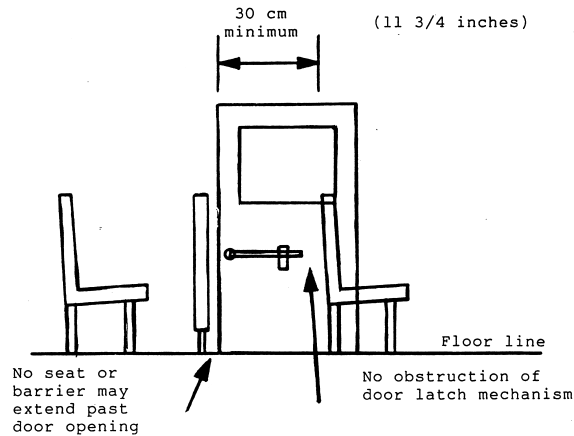

Figure 6 Minimum Side Emergency Exit Clearance Specifications

- (2) The requirements for emergency roof exits are as follows:
- (i) Each emergency roof exit shall be hinged on its forward side, and shall be operable from both inside and outside the vehicle.
 - (ii) In a school bus equipped with a single emergency exit, the exit shall be located as near as practicable to the midpoint of the passenger compartment.
 - (iii) In a bus equipped with two emergency roof exits:
 - (A) One emergency roof exit shall be located as near as practicable to a point equidistant between the midpoint of the passenger compartment and the foremost limit of the passenger compartment.
 - (B) The other emergency roof exit shall be located as near as practicable to a point equidistant between the midpoint of the passenger compartment and the rearmost point of the passenger compartment.
 - (iv) In a bus equipped with three or more emergency roof exits, the roof exits shall be installed so that, to the extent practicable, the longitudinal distance between each pair of adjacent roof exits is the same and equal to:
 - (A) The distance from the foremost point of the passenger compartment to the foremost roof exit.
 - (B) The distance from the rearmost point of the passenger compartment to the rearmost roof exit.

(v) Except as provided in subparagraph (vi), each emergency roof exit shall be installed with its longitudinal centerline coinciding with a longitudinal vertical plane passing through the longitudinal centerline of the school bus.

(vi) In a bus equipped with two or more emergency roof exits, for each roof exit offset from the longitudinal vertical plane specified in subparagraph (v), there shall be another roof exit offset from that plane an equal distance to the other side.

(vii) Each school bus emergency roof exit shall allow manual release of the exit by a single person, from both inside and outside the passenger compartment, using not more than two release mechanisms.

(viii) Each school bus emergency roof exit, after the release mechanism has been operated, shall be manually extendable by a single person to a position that permits an opening at least 41 centimeters—16 1/8 inches—high and 41 centimeters—16 1/8—wide.

(3) The requirements for emergency exit windows are as follows:

(i) A bus equipped with emergency exit windows shall have an even number of these windows, not counting a push-out rear window. Side emergency exit windows shall be evenly divided between the right and left sides of the bus.

(ii) Each school bus emergency exit window shall allow manual release of the exit by a single person, from inside the passenger compartment, using not more than two release mechanisms. Each release mechanism shall operate without the use of remote controls or tools, and notwithstanding a failure of the vehicle's power system. When the release mechanism is open and the vehicle's ignition is in the "on" position, a continuous warning shall be audible at the driver's seating position.

(4) The engine starting system of a bus may not operate if an emergency exit is locked from either inside or outside the bus. An emergency exit is considered locked if the release mechanism cannot be activated and the exit cannot be opened by a person at the exit without a key or other special device, or a combination or other special information.

(5) The requirements for emergency exit labeling are as follows:

(i) Each school bus emergency exit shall be labeled "Emergency Door" or "Emergency Exit," as appropriate, in letters at least 5 centimeters (2 inches) high, of a color that contrasts with its background. For emergency exit doors, the label shall be located at the top of, or directly above, the emergency exit door on both the inside and outside surfaces of the bus. The label for roof exits shall be located on an inside surface of the exit, or within 30 centimeters (11 3/4 inches) of the roof exit opening. For emergency exit windows, the label shall be located at the top of, or directly above, or at the bottom of the emergency exit window on both the inside and outside surfaces

of the bus. If the school bus is equipped with tinted windows, the emergency exit labeling may not be placed on the glass, unless it is placed on both the inside and outside.

(ii) Concise operating instructions describing the motions necessary to unlatch and open the emergency exit shall be located within 15 centimeters (5 15/16 inches) of the release mechanism on the inside surface of the bus. These instructions shall be in letters at least 1 centimeter (3/8 inches) high and of a color that contrasts with its background—for example: “Lift to Unlatch, Push or Open;” or “Turn Handle, Push Out to Open.”

(iii) Each opening for a required emergency exit shall be outlined around its outside opened perimeter with a minimum 3 centimeters—1 1/8 inches—wide retroreflective tape, either red, white or yellow in color, which meets the requirements of FMVSS No. 131. See Appendix A.

Authority

The provisions of this § 171.50 amended under the Vehicle Code, 75 Pa.C.S. §§ 4103, 4551—4553 and 6103.

Source

The provisions of this § 171.50 adopted August 19, 1983, effective August 20, 1983, 13 Pa.B. 2561; readopted December 4, 1987, effective December 5, 1987, 17 Pa.B. 5052; amended September 13, 1996, effective September 14, 1996, 26 Pa.B. 4411; amended November 26, 2003, effective November 29, 2003, 33 Pa.B. 5817; amended May 20, 2005, effective May 21, 2005, 35 Pa.B. 3039. Immediately preceding text appears at serial pages (301821) to (301827).

Cross References

This section cited in 67 Pa. Code § 171.47 (relating to color).

§ 171.51. Fire extinguisher.

(a) *Required.* Every school bus shall be equipped with at least one pressurized, multipurpose, dry chemical or halogenated agent fire extinguisher, mounted in a bracket in the driver’s compartment and readily accessible to the driver. The fire extinguisher shall be mounted as directed by the manufacturer. The fire extinguisher shall have a hose and nozzle and be in good and usable condition. A pressure gauge shall be mounted on the extinguisher so as to be easily read without removing the extinguisher from its mounted position.

(b) *Type.* The fire extinguisher shall be of a type meeting the Underwriters Laboratories, Inc. Standard 299 or 1093—see Appendix A—with a total rating of not less than 2 A-10 BC. The operating mechanism shall be sealed with a type of seal which may not interfere with the use of the fire extinguisher.

Authority

The provisions of this § 171.51 amended under the Vehicle Code, 75 Pa.C.S. §§ 4103, 4551—4553 and 6103.

Source

The provisions of this § 171.51 adopted August 4, 1978, effective July 1, 1979, 8 Pa.B. 2194; amended August 19, 1983, effective August 20, 1983, 13 Pa.B. 2561; readopted December 4, 1987, effective December 5, 1987, 17 Pa.B. 5052; amended September 13, 1996, effective September 14, 1996, 26 Pa.B. 4411. Immediately preceding text appears at serial page (122795).

§ 171.52. First aid.

(a) *First aid kit.* Every school bus shall have a removable moisture and dust-proof first aid kit, mounted in an accessible place within the driver's compartment. The first aid kit shall be mounted as directed by the manufacturer. The first aid kit shall be labeled and visible to the driver or its location shall be marked.

(b) *Content.* The first aid kit shall contain, at a minimum, the following items:

- (1) Two 1 inch × 2 1/2 yards rolls of nonlatex adhesive tape.
- (2) Twenty-four sterile gauze pads, 3 inches × 3 inches
- (3) One hundred 3/4 inch × 3 inches adhesive bandages.
- (4) Eight 2 inch bandage compresses.
- (5) Ten 3 inch bandage compresses.
- (6) Two 2 inches × 6 yards sterile gauze roller bandages.
- (7) Two nonsterile triangular bandages approximately 40 inches × 36 inches × 54 inches with 2 safety pins.
- (8) Three sterile gauze pads, 36 inches × 36 inches.
- (9) Three sterile eye pads.
- (10) One pair rounded end scissors.

(c) *Body fluid clean-up kit.* Every school bus shall have a removable and moisture proof body fluid clean-up kit. It shall be securely placed or mounted in an easily accessible location and labeled as a body fluid clean-up kit.

(d) *Surgical gloves and mouth barriers.* Either the first aid kit or the body fluid cleanup kit shall contain:

- (1) One pair of nonlatex surgical gloves.
- (2) One mouth barrier.

Authority

The provisions of this § 171.52 amended under the Vehicle Code, 75 Pa.C.S. §§ 4103, 4551—4553 and 6103.

Source

The provisions of this § 171.52 adopted August 4, 1978, effective July 1, 1979, 8 Pa.B. 2194; amended August 19, 1983, effective August 20, 1983, 13 Pa.B. 2561; readopted December 4, 1987, effective December 5, 1987, 17 Pa.B. 5052; amended September 13, 1996, effective September 14, 1996, 26 Pa.B. 4411; amended November 26, 2003, effective November 29, 2003, 33 Pa.B. 5817. Immediately preceding text appears at serial pages (219629) to (219630).

§ 171.53. Floor.

The following rules govern floor covering:

(1) The floor in the underseat area, including the tops of wheelhousing, driver's compartment and the toeboard, shall be covered with rubber floor covering or equivalent having a minimum overall thickness of .125 inch. Type A school buses may use manufacturer's standard floor covering in the driver's compartment.

(2) The floor covering in the aisle shall be of aisle type rubber or equivalent, wear resistant and ribbed. The minimum overall thickness shall be .187 inch measured from tops of ribs.

(3) Floor covering shall be permanently bonded to the floor and may not crack when subjected to sudden changes in temperature. Bonding or adhesive material shall be waterproof and shall be of the type recommended by the manufacturer of the floor covering material. Seams shall be sealed with waterproof sealer.

Source

The provisions of this § 171.53 adopted August 4, 1978, effective July 1, 1979, 8 Pa.B. 2194; amended August 19, 1983, effective August 20, 1983, 13 Pa.B. 2561; readopted December 4, 1987, effective December 5, 1987, 17 Pa.B. 5052. Immediately preceding text appears at serial page (83747).

§ 171.54. Heaters.

(a) The requirements for heaters are as follows:

(1) Heaters shall provide evenly distributed heat throughout the interior of the bus.

(2) At least one heater shall provide defrosting for the windshield, driver's side sash and entrance door.

(3) Heater hoses shall be adequately supported to guard against excessive wear due to vibration. The hoses may not dangle or rub against the chassis or sharp edges and may not interfere with or restrict the operation of any engine function. Heater hoses shall conform to applicable SAE Standards. See Appendix A. Heater lines on the interior of the bus shall be shielded to prevent scalding of the driver or passengers.

(4) A hot water heater system shall include a shutoff valve installed in the pressure and return lines at the engine. There shall be a water flow regulating valve installed for convenient operation by the driver. Type A school buses are exempt from this paragraph.

(5) Accessible bleeder valves shall be installed to remove air from the heater lines. The valves shall be installed in an appropriate place in the return lines of the heater.

(6) Heater motors, cores and fans shall be readily accessible for service. Access panels shall be provided as needed.

(b) Auxiliary fuel-fired heating systems are permitted, provided they comply with the following:

(1) The auxiliary heating system fuel shall utilize the same type fuel as specified for the vehicle engine.

(2) The heaters may be either of a direct hot air type or connected to the engine's coolant system.

(3) An auxiliary heating system, when connected to the engine's coolant system, may be used to preheat the engine coolant or preheat and add supplementary heat to the bus's heating system.

(4) Auxiliary heating systems shall be installed pursuant to the manufacturer's recommendations and may not direct exhaust in a manner that will endanger bus passengers.

(5) Auxiliary heating systems which operate on diesel fuel shall be capable of operating on #1, #2 or blended diesel fuel without the need for system adjustment.

(6) Auxiliary heating systems shall be low voltage.

(7) Auxiliary heating systems shall comply with all applicable Federal Motor Vehicle Safety Standards, including FMVSS 301 as well as SAE test procedures.

Authority

the provisions of this § 171.54 amended under the Vehicle Code, 75 Pa.C.S. §§ 4103, 4551—4553 and 6103.

Source

The provisions of this § 171.54 adopted August 4, 1978, effective July 1, 1979, 8 Pa.B. 2194; amended August 19, 1983, effective August 20, 1983, 13 Pa.B. 2561; readopted December 4, 1987, effective December 5, 1987, 17 Pa.B. 5052; amended September 13, 1996, effective September 14, 1996, 26 Pa.B. 4411; amended May 20, 2005, effective May 21, 2005, 35 Pa.B. 3039. Immediately preceding text appears at serial pages (301829) to (301830).

§ 171.55. Identification.

(a) *Required.* Every school bus body shall bear the words “**SCHOOL BUS**” in black letters at least 8 inches high on both the front and the rear of the body, or on signs attached thereto. Lettering shall be placed as high as possible without impairment of its visibility. Lettering shall conform to “Series B” of Standard Alphabets for Highway Signs.

(b) *Identification number.* A school bus shall display an identification number consisting of no more than 4 black numbers, letters or a combination of numbers and letters. The numbers or letters shall be a minimum 5 inches in height and shall be displayed in a prominent location on the front, rear and on both sides of the bus. On a school bus with a rounded front, the identification number displayed on the front of the bus may be displayed on the black front bumper in

yellow numbers, letters, or a combination of numbers and letters, in lieu of black numbers, letters, or a combination of numbers and letters on the front of the yellow bus body.

(c) *School, bus company and manufacturer markings.* School buses shall have the name of the school district, private or parochial school, school bus contractor, or school bus owner clearly visible, lettered on each side of the school bus body in the upper body belt band area as close as practical to the bottom ledge of the bottom window sash in letters of not less than 4 inches in height. Lettering shall be in black or National School Bus Yellow, depending on the contrasting background color. See Appendix B. A paper or vinyl route identification number or symbols may be placed in the rear of the first right or left passenger window, or both. The bus contractor may have his name or the name of the company in letters no larger than 3 inches in height. The dealer identification insignia may be displayed, in an area not to exceed 6 inches in height by 12 inches in width. The manufacturer's insignias may be displayed. Pennsylvania Public Utility Commission certification number and the U.S. DOT identification number, and any other required commercial vehicle markings may be displayed.

(d) *Roof-top identification.* School buses may display the first eight digits of the title number on the roof in numbers of at least 12.75 inches and not more than 15 inches in height. Lettering shall be in black reflective material and placed in a longitudinal column with the first digit beginning at the front and the last digit ending towards the rear of the school bus as illustrated as follows:

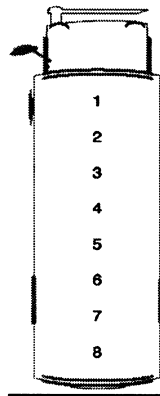

(e) *Additional markings.* Except as set forth in this section, signs or lettering are not permitted.

Authority

The provisions of this § 171.55 amended under the Vehicle Code, 75 Pa.C.S. §§ 4103, 4551—4553 and 6103.

Source

The provisions of this § 171.55 adopted August 4, 1978, effective July 1, 1979, 8 Pa.B. 2194; amended August 19, 1983, effective August 20, 1983, 13 Pa.B. 2561; readopted December 4, 1987, effective December 5, 1987, 17 Pa.B. 5052; amended September 13, 1996, effective September 14, 1996, except subsection (b) effective September 14, 1997, 26 Pa.B. 4411; amended November 26, 2003, effective November 29, 2003, 33 Pa.B. 5817; amended May 20, 2005, effective May 21, 2005, 35 Pa.B. 3039. Immediately preceding text appears at serial pages (301830) to (301831).

§ 171.56. Inside height.

Inside body height of a school bus shall be 72 inches or more, measured metal to metal, at all points on the longitudinal centerline from the front vertical bow to the rear vertical bow or to the rear interior ceiling mounted air-conditioning unit. Inside body height of Type A school buses shall be 62 inches or more.

Authority

The provisions of this § 171.56 amended under the Vehicle Code, 75 Pa.C.S. §§ 4103, 4551—4553 and 6103.

Source

The provisions of this § 171.56 adopted August 4, 1978, effective July 1, 1979, 8 Pa.B. 2194; amended August 19, 1983, effective August 20, 1983, 13 Pa.B. 2561; readopted December 4, 1987, effective December 5, 1987, 17 Pa.B. 5052; amended September 13, 1996, effective September 14, 1996, 26 Pa.B. 4411. Immediately preceding text appears at serial pages (140081) to (140082).

§ 171.57. Insulation.

The requirements for the use of insulation are as follows:

- (1) Ceiling and walls shall be insulated with fire resistant material of a type approved by the Underwriters Laboratories, Inc. Standard 723. See Appendix A.
- (2) If floor insulation is used it shall be 5-ply, 5/8-inches thick or it shall equal or exceed properties of exterior type softwood plywood, C-D Grade as specified in Standard PS1-83 issued by the United States Department of Commerce. See Appendix A.

Authority

The provisions of this § 171.57 amended under the Vehicle Code, 75 Pa.C.S. §§ 4103, 4551—4553 and 6103.

Source

The provisions of this § 171.57 adopted August 19, 1983, effective August 20, 1983, 13 Pa.B. 2561; readopted December 4, 1987, effective December 5, 1987, 17 Pa.B. 5052; amended September 13, 1996, effective September 14, 1996, 26 Pa.B. 4411. Immediately preceding text appears at serial page (140082).

§ 171.58. Interior.

The requirements for the interior of school buses are as follows:

- (1) The interior of every school bus shall be free of unnecessary projections likely to cause injury. This standard requires inner lining on ceilings and walls. If the ceiling is constructed so as to contain lapped joints, the forward panel shall be lapped by the rear panel, and exposed edges shall be beaded, hemmed, flanged or otherwise treated to minimize sharp edges.
- (2) Every school bus shall meet the requirements of FMVSS No. 302, as to the flammability of interior materials. See Appendix A.
- (3) Book racks or luggage racks are not permitted.
- (4) Interior radio/stereo speakers shall be of the flush mounted type. Exposed parts shall be treated to minimize sharp edges.
- (5) The driver's area forward of the foremost padded barriers shall permit the mounting of required safety equipment and vehicle operating equipment.
- (6) The requirements for air-conditioning units are as follows:
 - (i) Persons installing air-conditioning units in school buses after the vehicle's original manufacture date shall install the equipment in accordance with manufacturer's specification and applicable FMVSS.
 - (ii) Interior ceiling-mounted air-conditioning units, mounted above the seats within the head protection zone or at the rear of the bus, shall be padded with materials meeting FMVSS No. 302 to an extent to insure compliance with the head impact test requirements of FMVSS No. 222. See Appendix A.
 - (iii) This paragraph does not prohibit the installation of air-conditioning units in locations other than those described in subparagraph (ii). Air-conditioning units may be installed in other locations if labeled as described in subparagraph (i).

Authority

The provisions of this § 171.58 amended under the Vehicle Code, 75 Pa.C.S. §§ 4103, 4551—4553 and 6103.

Source

The provisions of this § 171.58 adopted August 19, 1983, effective August 20, 1983, 13 Pa.B. 2561; readopted December 4, 1987, effective December 5, 1987, 17 Pa.B. 5052; amended September 13, 1996, effective September 14, 1996, 26 Pa.B. 4411; amended May 20, 2005, effective May 21, 2005, 35 Pa.B. 3039. Immediately preceding text appears at serial pages (301832) to (301833).

§ 171.59. Lamps and signals.

- (a) *General rule.* All lamps, signals, reflectors and their installation must be in conformance with applicable FMVSS and SAE standards.
- (b) *Exterior lamps.* Exterior lamps shall meet the requirements of FMVSS No. 108.
- (c) *Flashing signal lamps and stop signal arm devices.* The requirements for flashing signal lamps and stop signal arm devices are as follows:

(1) *Signal lamps.* Every school bus shall be equipped with 8-way warning lamps consisting of two red and two amber alternately flashing signal lamps at the rear of the vehicle and two red and two amber alternately flashing signal lamps at the front of the vehicle.

(i) Each amber signal lamp shall be located near each red signal lamp, at the same level, but closer to the vertical centerline of the school bus.

(ii) The system shall be wired so that the amber signal lamps are activated manually, and if activated, are automatically deactivated and the red signal lamps automatically activated when the school bus service door is opened.

(iii) Amber and red warning lamps must alternate between left and right at a minimum rate of 60 flashes per minute.

(iv) LED and/or strobe lights may be used in the 8-way warning lamps system.

(v) If strobe lights are used, the strobe effect must appear as a flash of varying intensity and not separate flashes. All amber and red warning lamps must strobe in the same pattern. The same pattern is the same number of flashes per lamp before the system alternates to the other side.

(vi) The area around the lens of each alternately flashing signal lamp shall be of a black contrasting color. The use of visors or hoods with an appropriate black background to fit the shape of the visors or hoods and the roofcap is permitted.

(vii) Flashers for alternately flashing red and amber signal lamps shall be enclosed in the school bus body in a readily accessible location.

(2) *Stop signal arm devices.* A school bus may be equipped with strobe or LED flashing stop signal, or both. The signal may be equipped with two flashing strobe or LED lights, or both, at least 4 inches in diameter, red in color and double faced. Stop signal arm devices on school buses shall comply with FMVSS No. 131—See Appendix A—and the following requirements:

(i) The stop signal arm shall be a regular octagon which is at least 450 mm × 450 mm—17.72 inches × 17.72 inches—in diameter.

(ii) The stop signal arm shall be red on both sides, except as provided in subparagraphs (iii)—(v).

(iii) The stop signal arm shall have a white border at least 12 mm—0.47 inch—wide on both sides, except as provided in subparagraph (v).

(iv) The stop signal arm shall have the word “STOP” displayed in white upper-case letters on both sides, except as provided in subparagraph (v). The letters shall be at least 150 mm—5.9 inches—in height and have a stroke width of at least 20 mm—0.79 inch.

(v) If two stop signal arms are installed on a school bus, the rearmost stop signal arm may not contain lettering, symbols or markings on the forward side.

(vi) The stop signal arm shall comply with clause (A) or (B), or both.

(A) The entire surface of both sides of the stop signal arm shall be reflectorized with Type III reflectorized material that meets the minimum specific intensity requirements of FMVSS No. 125. See Appendix A. If two stop signal arms are installed on a school bus, the forward side of the rearmost stop signal arm may not be reflectorized.

(B) Each side of the stop signal arm shall have at least two red lamps that meet the requirements of SAE Standard J578. See Appendix A. The lamps shall be centered on the vertical centerline of the stop arm. One of the lamps shall be located at the extreme top of the stop arm and the other at its extreme bottom.

(vii) The stop signal arm shall be installed on the left side of the bus.

(viii) The stop signal arm shall be located so that, when in the extended position, the following requirements are met:

(A) The stop signal arm is perpendicular to the side of the bus, $\pm 5^\circ$ F.

(B) The top edge of the sign is parallel to and within 6 inches of a horizontal plane tangent to the lower edge of the driver's window frame.

(C) The vertical centerline of the stop sign is at least 9 inches away from the side of the school bus.

(ix) If a rearmost stop signal arm is installed on a school bus, the stop signal arm shall comply with subparagraphs (vii) and (viii).

(x) The stop signal arm shall be automatically extended so that it complies with subparagraph (viii), at a minimum, whenever the red signal lamps required by FMVSS No. 108, S5.1.4—See Appendix A—are activated; except that a device may be installed that prevents the automatic extension of a stop signal arm. The mechanism for activating the device shall be within the reach of the driver. While the device preventing automatic extension is activated, a continuous or intermittent signal audible to the driver shall sound. The audible signal may be equipped with a timing device but shall require the signal to sound for at least 60 seconds. If a timing device is used, it shall automatically recycle each time the service entry door is opened while the engine is running and the manual override is engaged.

(xi) The lamps on each side of the stop signal arm, when operated at the manufacturer's design load, shall flash at a minimum rate of 60 flashes per minute.

(xii) The stop signal arm and components shall comply with SAE Standard J1133. See Appendix A.

(3) *Exception.* A multifunction school activity bus is exempt from the flashing signal lamps and stop arm device requirements of this section. However, a multifunction school activity bus which is not in compliance with the requirements of § 171.18 (relating to color) may not have 8-way warning lamps and stop arm devices.

(d) *Interior lamps.* Interior lamps shall adequately illuminate the aisle and step well.

(e) *Turn signal and stop lamps.* The rear turn signal lamps shall be at least 7 inches in diameter, or if in a shape other than round, a minimum of 38 square inches, and meet SAE Standards. These signals shall be connected to the chassis hazard warning switch to cause simultaneous flashing of the turn signal lamps when needed as vehicular traffic hazard warning. The turn signal lamps shall be placed as wide apart as practical and their centerline shall be approximately 8 inches below the rear windows. Type A school bus lamps shall be 21 square inches in lens area. Just inside the turn signal, there shall be installed at the same elevation, two 7 inch diameter stop lamps, or if in a shape other than round, a minimum of 38 square inches. The lamps shall flash at a rate of 60—120 flashes per minute.

(f) *Monitor.* If a school bus is equipped with indicators to monitor the front and rear lamps, it shall be mounted in full view of the driver. If the full circuit current passes through the indicator, each circuit shall be protected by a fuse, circuit breaker or multiplex electrical circuit technology.

Authority

The provisions of this § 171.59 amended under the Vehicle Code, 75 Pa.C.S. §§ 4103, 4551—4553 and 6103.

Source

The provisions of this § 171.59 adopted August 19, 1983, effective August 20, 1983, 13 Pa.B. 2561; readopted December 4, 1987, effective December 5, 1987, 17 Pa.B. 5052; amended July 7, 1989, effective July 8, 1989, 19 Pa.B. 2957; amended September 13, 1996, effective September 14, 1996, 26 Pa.B. 4411; amended November 26, 2003, effective November 29, 2003, 33 Pa.B. 5817; amended May 20, 2005, effective May 21, 2005, 35 Pa.B. 3039. Immediately preceding text appears at serial pages (301833) to (301836).

Cross References

This section cited in 67 Pa. Code § 171.47 (relating to color); and 67 Pa. Code § 171.136 (relating to signal lamps).

§ 171.60. Metal treatment.

(a) *General.* Metal used in the construction of a school bus body shall be zinc or aluminum coated or treated by an equivalent process before the school bus is constructed. This requirement includes such items as structural members, inside and outside panels, door panels and floor sills. Excluded from this requirement are such items as door handles, grab handles, interior decorative parts and other interior plated parts.

(b) *Painted parts.* Metal parts that are painted shall first be chemically cleaned, etched, zinc phosphate coated and zinc chromate or epoxy primed or conditioned by an equivalent process.

(c) *Special areas.* Particular attention shall be given lapped surfaces, welded connections of structural members, cut edges, punched or drilled hole areas in

sheet metal, closed or box sections, unvented or undrained areas and surfaces subjected to abrasion during school bus operation.

(d) *Testing.* As evidence that the requirements of this section have been met, samples of materials and sections used in construction of the school bus body, when subjected to a 1000-hour salt spray test as provided for in the latest revision of ASTM Standard B-117—see Appendix A—may not lose more than 10% of material by weight.

Source

The provisions of this § 171.60 adopted August 19, 1983, effective August 20, 1983, 13 Pa.B. 2561; readopted December 4, 1987, effective December 5, 1987, 17 Pa.B. 5052. Immediately preceding text appears at serial pages (83750) to (83751).

§ 171.61. Mirrors.

(a) *Interior mirror.* Every school bus shall be equipped with an interior mirror which shall be made of either clear view laminated glass or clear view glass bonded to backing which retains the glass in the event of breakage. The mirror shall have rounded corners and protected edges. Type A school buses shall have a mirror of at least 6 inches by 16 inches. Types B, C and D school buses shall have a mirror of at least 6 inches by 30 inches.

(b) *Outside rearview mirrors.* Each school bus shall have outside rearview mirrors of unit magnification, installed with stable supports on both sides of the vehicle. Each mirror shall have at least 50 square inches of reflective surface. The mirrors shall be located so as to provide the driver a view to the rear along both sides of the vehicle and shall be adjustable both in the horizontal and vertical directions to view the rearward scene.

(c) *Outside cross view mirror.* Each school bus, except one which is a forward control vehicle, shall have a convex mirror which complies with the following:

(1) The convex mirror shall have a radius of curvature not less than 3.5 inches and not more than 25 inches. A convex mirror whose radius of curvature at its periphery is not less than 12 inches and not more than 25 inches shall have a surface area which is not less than 40 square inches. A convex mirror whose radius of curvature at any point on the mirror is less than 12 inches shall have a projected area of not less than 40 square inches, measured on a plane at a right angle to the mirror's axis. A convex mirror with a nonuniform radius shall comply with the following criteria:

(i) The radius at the periphery of the mirror may not be less than 75% of the radius at the center of the mirror.

(ii) Along the intersection of any plane containing the axis of symmetry of the mirror and the surface of the mirror, the length of the radius, as measured by a spherometer, shall be monotonically nonincreasing when moving from the axis of symmetry to the periphery along the intersection.

(iii) Along the intersection described in subparagraph (ii), the slope of the surface of the mirror may not have any discontinuities.

(2) The mirror shall be installed with a stable support, and mounted so as to provide the driver a view of the front bumper and the area in front of the bus.

(d) *Prohibited mirrors.* Stick-on convex mirrors and convex mirrors which are an integral part of the rear view mirror are prohibited.

Authority

The provisions of this § 171.61 amended under the Vehicle Code, 75 Pa.C.S. §§ 4103, 4551—4553 and 6103.

Source

The provisions of this § 171.61 adopted August 19, 1983, effective August 20, 1983, 13 Pa.B. 2561; readopted December 4, 1987, effective December 5, 1987, 17 Pa.B. 5052; amended September 13, 1996, effective September 14, 1996, 26 Pa.B. 4411. Immediately preceding text appears at serial pages (140085) to (140086).

Cross References

This section cited in 67 Pa. Code § 171.22 (relating to fenders, front on Type C school buses).

§ 171.62. Mounting.

The chassis frame shall support the rear body cross member. The school bus body shall be attached to the chassis frame at each main floor sill, except where chassis components interfere, in such a manner as to prevent shifting or separation of the body from the chassis under severe operation conditions.

Source

The provisions of this § 171.62 adopted August 19, 1983, effective August 20, 1983, 13 Pa.B. 2561; readopted December 4, 1987, effective December 5, 1987, 17 Pa.B. 5052. Immediately preceding text appears at serial page (83752).

§ 171.63. Overall length.

The overall length of a school bus may not exceed 40 feet.

Source

The provisions of this § 171.63 adopted August 19, 1983, effective August 20, 1983, 13 Pa.B. 2561; readopted December 4, 1987, effective December 5, 1987, 17 Pa.B. 5052. Immediately preceding text appears at serial page (83752).

§ 171.64. [Reserved].**Source**

The provisions of this § 171.64 adopted August 19, 1983, effective August 20, 1983, 13 Pa.B. 2561; readopted December 4, 1987, effective December 5, 1987, 17 Pa.B. 5052; amended July 7, 1989, effective July 8, 1989, 19 Pa.B. 2957; reserved May 20, 2005, effective May 21, 2005, 35 Pa.B. 3039. Immediately preceding text appears at serial page (219639).

§ 171.65. Pry (wrecking) bar.

A pry bar at least 24 inches in length shall be mounted in a position readily accessible to the driver. School buses originally equipped with a fire axe shall replace it with a pry bar, if and when replacement is necessary.

Source

The provisions of this § 171.65 adopted August 19, 1983, effective August 20, 1983, 13 Pa.B. 2561; readopted December 4, 1987, effective December 5, 1987, 17 Pa.B. 5052. Immediately preceding text appears at serial page (83752).

§ 171.66. Rub rails.

The following apply to rub rails:

(1) There shall be one rub rail located on each side of the school bus, approximately at seat level, which shall extend from the rear side of the entrance door completely around the school bus body—except the emergency door—to the point of curvature near the outside cowl on the left side. For Types A and B school buses using the chassis manufacturer's body, or Types C and D school buses using a rear luggage or a rear engine compartment, rub rails need not extend around the rear corners.

(2) There shall be one rub rail located approximately at the floor line which shall cover the same longitudinal area as the upper rub rail, except at the wheelhousing, and shall extend only to the radii of the right and left rear corners. Type A school buses are exempt from this requirement.

(3) There shall be one rub rail located as low as possible on the lower body panel. It shall cover the same longitudinal area as the rub rail described in paragraph (2). Types A and B school buses are exempt from this paragraph.

(4) Rub rails shall be attached at each body post and other upright structural members.

(5) Rub rails shall be 4 inches or more in width, shall be of 16-gauge steel or suitable material of equivalent strength and shall be constructed in corrugated or ribbed fashion.

(6) Rub rails shall be applied outside the body or outside the body posts and shall be firmly attached in order to assist in preventing penetration. Pressed-in or snap-on rub rails do not satisfy this paragraph.

Source

The provisions of this § 171.66 adopted August 19, 1983, effective August 20, 1983, 13 Pa.B. 2561; readopted December 4, 1987, effective December 5, 1987, 17 Pa.B. 5052. Immediately preceding text appears at serial pages (83752) to (83753).

§ 171.67. Traction assist devices.

School buses may be equipped with sanders and automatic tire chains. Sanders and automatic tire chains shall be installed in accordance with the manufacturer's installation procedures.

Authority

The provisions of this § 171.67 amended under the Vehicle Code, 75 Pa.C.S. §§ 4551—4553 and 6103.

Source

The provisions of this § 171.67 adopted August 19, 1983, effective August 20, 1983, 13 Pa.B. 2561; readopted December 4, 1987, effective December 5, 1987, 17 Pa.B. 5052; amended May 20, 2005, effective May 21, 2005, 35 Pa.B. 3039. Immediately preceding text appears at serial page (219640).

§ 171.68. Seat belts.

(a) *Seat belt for the driver.* A Type 2 seat belt meeting the requirements of FMVSS Nos. 208 and 209—See Appendix A—shall be provided for the driver. The belt shall be equipped with a retractor of sufficient quality and strength to keep the belt retracted and off the floor when not in use. The belt shall be anchored in accordance to FMVSS No. 210—See Appendix A.

(b) *Seat belts for the driver and all other designated seating positions.* Every Type A school bus shall be equipped with an integral Type 2 seat belt assembly at the driver's designated seating position and at the right front passenger's designated seating position, if any. All other designated seating positions shall have a Type 1 or Type 2 seat belt assembly. Seat belt assemblies shall comply with FMVSS Nos. 208, 209 and 210—See Appendix A.

(c) *Web cutters.* Every school bus equipped with passenger seat belts shall have at least one web cutter securely mounted in a visible location in the driver's compartment.

Authority

The provisions of this § 171.68 amended under the Vehicle Code, 75 Pa.C.S. §§ 4103, 4551—4553 and 6103.

Source

The provisions of this § 171.68 adopted August 19, 1983, effective August 20, 1983, 13 Pa.B. 2561; readopted December 4, 1987, effective December 5, 1987, 17 Pa.B. 5052; amended September 13, 1996, effective September 14, 1996, 26 Pa.B. 4411; amended May 20, 2005, effective May 21, 2005, 35 Pa.B. 3039. Immediately preceding text appears at serial page (219640).

§ 171.69. Seats and crash barriers.

The requirements for seats and crash barriers are as follows:

- (1) Seats shall have a minimum seating depth of 15 inches.
- (2) A seating space at least 13 inches wide shall be provided for each passenger.
- (3) Each seat, seat back cushion and crash barrier shall be covered with a material having at least a 42-ounce finished weight, 54 inches width, and finished vinyl coating of 1.06 broken twill, or other material with equal tensile strength, tear strength, seam strength, adhesion strength, resistance to abrasion, resistance to cold and flex separation. Seat materials shall comply with FMVSS No. 302. See Appendix A.
- (4) Seats not designed to meet FMVSS No. 222—See Appendix A—are not permitted. Specially equipped school buses, flip seats which comply with FMVSS No. 217—See Appendix A—and school bus seats designed with an integrated child restraint seat which complies with FMVSS No. 213—See Appendix A—are exempt from this paragraph. Child safety seats which comply with FMVSS No. 213 are also exempt from this paragraph if they are used and secured at all times as designated by the manufacturer.
- (5) Except as set forth in paragraphs (6)—(11), the backs of all seats of similar size shall be of the same width at the top, of the same height above the floor, and shall slant at the same angle with the floor. A school bus seat designed with an integrated child restraint seat, which complies with FMVSS No. 213, shall have a crash barrier or have a seat back of similar size or height in front of it.
- (6) Each school bus passenger seat shall have a minimum seat back height of 24 inches measured from the top of the seat cushion.
- (7) The horizontal distance between passenger seats may not be more than 28 inches measured from the front of the seat back cushion forward to the back of the restraining barrier.
- (8) Seats shall be forward-facing.
- (9) Seats shall be installed in a manner to prevent the seats from disengaging from the seat frame under extraordinary operating conditions. Seats may not have springs protruding and may not have tears greater than 1 inch.
- (10) Seats and anchorages shall comply with FMVSS No. 222. See Appendix A.
- (11) A padded barrier shall be placed in front of all forward-facing passenger seats that do not have another seat in front of them, as required by FMVSS No. 222. See Appendix A.

Authority

The provisions of this § 171.69 amended under the Vehicle Code, 75 Pa.C.S. §§ 4103, 4551—4553 and 6103.

Source

The provisions of this § 171.69 adopted August 19, 1983, effective August 20, 1983, 13 Pa.B. 2561; readopted December 4, 1987, effective December 5, 1987, 17 Pa.B. 5052; amended September 13, 1996, effective September 14, 1996, 26 Pa.B. 4411; amended May 20, 2005, effective May 21, 2005, 35 Pa.B. 3039. Immediately preceding text appears at serial pages (219641) to (219642).

§ 171.70. Steps.

The requirements for steps are as follows:

- (1) The lower step at the service door may be not less than 12 inches and not more than 16 inches from the ground, based on standard chassis specifications.
- (2) The service door entrance may be equipped with at least a two-step stepwell. Risers in each case shall be approximately equal. When a plywood floor is used on steel, the differential may be increased by the thickness of the plywood used. When a three-step stepwell is used, the first step at the service door shall be approximately 10 to 14 inches from the ground when the school bus is empty, based on standard chassis specifications. Type D school buses shall have at least a three-step stepwell with the first step at the service door 12 to 16 inches from the ground.
- (3) Steps shall be enclosed to prevent accumulation of ice and snow.
- (4) Steps may not protrude beyond the side body line.
- (5) A grab handle at least 20 inches in length shall be provided in an unobstructed location inside the doorway. The grab handle shall be designed or installed to prevent items of school children's clothing, personal items or an appendage from being snagged in the grab handle or door.
- (6) Steps on Types A and B school buses may be the manufacturer's standard.
- (7) Steps, including those in the floor line platform area, shall be covered with 3/16-inch rubber floor covering or other nonskid material that is equal in wear and abrasion resistance to top grade rubber.
- (8) The step tread material shall be permanently bonded to a durable backing material that is resistant to corrosion.
- (9) The step tread shall have a 1 1/2 inch white nosing as an integral piece without any joint.
- (10) The requirements for the rubber portion of step treads are as follows:
 - (i) Special compounding shall be used to allow for good abrasion resistance and a high coefficient of friction.
 - (ii) The rubber shall be flexible enough to allow it to be bent around a 1/2 inch mandrel both at 130°F and 20°F, without breaking or cracking.

Authority

The provisions of this § 171.70 amended under the Vehicle Code, 75 Pa.C.S. §§ 4103, 4551—453 and 6103.

Source

The provisions of this § 171.70 adopted August 19, 1983, effective August 20, 1983, 13 Pa.B. 2561; readopted December 4, 1987, effective December 5, 1987, 17 Pa.B. 5052; amended September 13, 1996, effective September 14, 1996, 26 Pa.B. 4411; amended May 20, 2005, effective May 21, 2005, 35 Pa.B. 3039. Immediately preceding text appears at serial pages (219642) and (301837).

§ 171.71. Stirrup steps.

There shall be at least one folding stirrup step or recessed foothold and suitably located handles on each side of the front of the body for easy accessibility for cleaning the windshield and lamps, except when the windshield and lamps are easily accessible from the ground. This section does not apply to vehicles not originally manufactured as school buses. A step, in lieu of the stirrup steps, is permitted in or on the front bumper for a Type D school bus.

Source

The provisions of this § 171.71 adopted August 19, 1983, effective August 20, 1983, 13 Pa.B. 2561; readopted December 4, 1987, effective December 5, 1987, 17 Pa.B. 5052. Immediately preceding text appears at serial page (83754).

§ 171.72. Storage compartment.

If tools, tire chains or tow chains are carried on the school bus, a container of adequate strength and capacity shall be provided. The container shall be located inside or outside the passenger compartment. If the container is located inside the passenger compartment, it shall have a cover which is capable of being securely latched. A seat cushion may not serve this purpose. The container shall also be capable of being fastened to the floor in a place convenient to either the service or emergency door.

Authority

The provisions of this § 171.72 amended under the Vehicle Code, 75 Pa.C.S. §§ 4103, 4551—4553 and 6103.

Source

The provisions of this § 171.72 adopted August 19, 1983, effective August 20, 1983, 13 Pa.B. 2561; readopted December 4, 1987, effective December 5, 1987, 17 Pa.B. 5052; amended September 13, 1996, effective September 14, 1996, 26 Pa.B. 4411. Immediately preceding text appears at serial pages (122805) to (122806).

§ 171.73. Sun shield.

(a) An interior adjustable transparent sun shield, with a finished edge and at least 6 inches by 30 inches shall be installed in Types B, C and D school buses in a position convenient for use by the driver.

(b) A sun shield (visor) shall be installed according to manufacturers standard on all Type A school buses. Additionally, Type A school buses may use an interior adjustable transparent sun shield, at least than 6 inches by 16 inches.

Authority

The provisions of this § 171.73 amended under the Vehicle Code, 75 Pa.C.S. §§ 4103, 4551—4553 and 6103.

Source

The provisions of this § 171.73 adopted August 19, 1983, effective August 20, 1983, 13 Pa.B. 2561; readopted December 4, 1987, effective December 5, 1987, 17 Pa.B. 5052; amended September 13, 1996, effective September 14, 1996, 26 Pa.B. 4411; amended May 20, 2005, effective May 21, 2005, 35 Pa.B. 3039. Immediately preceding text appears at serial pages (301837) to (301838).

§ 171.74. [Reserved].**Source**

The provisions of this § 171.74 adopted August 19, 1983, effective August 20, 1983, 13 Pa.B. 2561; readopted December 4, 1987, effective December 5, 1987, 17 Pa.B. 5052; reserved September 13, 1996, effective September 14, 1996, 26 Pa.B. 4411. Immediately preceding text appears at serial page (122806).

§ 171.74a. Crossing control arm.

School buses shall be equipped with a crossing control arm which shall be automatically activated whenever the bus is stopped with the red warning signals in use.

- (1) The crossing control arm shall meet or exceed SAE Standard J1133.
- (2) The crossing control arm shall be mounted on the right side of the front bumper and may not open more than 90°.
- (3) The crossing control arm shall extend a minimum of 60 inches from the front bumper when in the extended position.
- (4) The crossing control arm shall extend simultaneously with the stop arm by means of the stop arm controls.
- (5) The crossing control arm shall incorporate system connectors (electrical, vacuum or air) at the gate and shall be easily removable to allow for towing of the school bus.
- (6) All components of the crossing control arm and all connections shall be waterproofed.
- (7) If the crossing control arm is not constructed of noncorrosive or nonferrous material, it shall be zinc-coated or aluminum-coated or treated by equivalent process.
- (8) There may not be sharp edges or projections on the crossing control arm that could cause hazard or injury to students.
- (9) A multifunction school activity bus is not required to be in compliance with this section.

Authority

The provisions of this § 171.74a issued under the Vehicle Code, 75 Pa.C.S. §§ 1504, 1508, 1509, 4551—4553 and 6103.

Source

The provisions of this § 171.74a adopted November 26, 2003, effective November 29, 2003, 33 Pa.B. 5817; amended May 20, 2005, effective May 21, 2005, 35 Pa.B. 3039. Immediately preceding text appears at serial page (301838).

§ 171.75. Undercoating.

The entire underside of the school bus body, including floor sections, cross members and below floor line side panels, shall be coated with a compound to prevent rust which meets or exceeds Federal Specification TT-C-520b. See Appendix A.

Source

The provisions of this § 171.75 adopted August 19, 1983, effective August 20, 1983, 13 Pa.B. 2561; readopted December 4, 1987, effective December 5, 1987, 17 Pa.B. 5052. Immediately preceding text appears at serial page (100995).

§ 171.76. Ventilation.

The requirements for the ventilating system are as follows:

- (1) The school bus body shall be equipped with a ventilating system.
- (2) If used, auxiliary fans for the left or right side of the bus shall be placed in a location where they can be adjusted by the driver for their maximum effectiveness. These fans shall be 6 inches in diameter. The fan blades shall be covered with a protective cage and each fan shall be controlled by a separate switch.

Authority

The provisions of this § 171.76 amended under the Vehicle Code, 75 Pa.C.S. §§ 4103, 4551—4553 and 6103.

Source

The provisions of this § 171.76 adopted August 19, 1983, effective August 20, 1983, 13 Pa.B. 2561; readopted December 4, 1987, effective December 5, 1987, 17 Pa.B. 5052; amended September 13, 1996, effective September 14, 1996, 26 Pa.B. 4411; amended May 20, 2005, effective May 21, 2005, 35 Pa.B. 3039. Immediately preceding text appears at serial page (301839).

§ 171.77. Wheelhousing.

The requirements for wheelhousing are as follows:

- (1) The wheelhousing opening shall allow for easy tire removal and service.
- (2) The wheelhousing shall be so constructed as to prevent dust, water or fumes from entering the body. The wheelhousing shall be constructed of 16-gauge steel, or other material of equal strength.
- (3) The inside height of the wheelhousing above the floor line may not exceed 12 inches.

- (4) The wheelhousing shall provide clearance for the installation and use of tire chains on single and dual power driving wheels.
- (5) No part of a raised wheelhousing may extend into the emergency door opening.

Authority

The provisions of this § 171.77 amended under the Vehicle Code, 75 Pa.C.S. §§ 4103, 4551—4553 and 6103.

Source

The provisions of this § 171.77 adopted August 19, 1983, effective August 20, 1983, 13 Pa.B. 2561; readopted December 4, 1987, effective December 5, 1987, 17 Pa.B. 5052; amended September 13, 1996, effective September 14, 1996, 26 Pa.B. 4411. Immediately preceding text appears at serial page (122807).

§ 171.78. Windows.

The following apply to windows:

- (1) Each full side window shall provide an unobstructed emergency opening at least 9 inches high and 22 inches wide, obtained by lowering the window.
- (2) School buses shall be equipped with split sash windows. Push-out type windows may be used.
- (3) Glass in the windshield, windows and doors shall be of approved safety glazing so mounted that the identifying designation is visible, and of sufficient quality to prevent distortion of view in any direction. Glazing materials shall comply with FMVSS No. 205. See Appendix A. Glass may be mounted in a conventional rubber gasket or affixed to the body by a bonding process.
- (4) Exposed edges of glass shall be banded or have a finished edge.

Authority

The provisions of this § 171.178 amended under the Vehicle Code, 75 Pa.C.S. §§ 4551—4553 and 6103.

Source

The provisions of this § 171.78 adopted August 4, 1978, effective July 1, 1979, 8 Pa.B. 2194; amended August 19, 1983, effective August 20, 1983, 13 Pa.B. 2561; amended September 20, 1985, effective retroactively, 15 Pa.B. 3350; readopted December 4, 1987, effective December 5, 1987, 17 Pa.B. 5052; amended May 20, 2005, effective May 21, 2005, 35 Pa.B. 3039. Immediately preceding text appears at serial page (219645).

§ 171.79. Windshield washers.

A windshield washer system shall be installed and in safe operating condition.

Source

The provisions of this § 171.79 adopted August 19, 1983, effective August 20, 1983, 13 Pa.B. 2561; readopted December 4, 1987, effective December 5, 1987, 17 Pa.B. 5052. Immediately preceding text appears at serial page (100995).

§ 171.80. Windshield wipers.

A windshield wiping system, two-speed or more, shall be installed and in safe operating condition. The wipers shall be operated by one or more air or electric motors of sufficient power to operate wipers.

Authority

The provisions of this § 171.80 amended under the Vehicle Code, 75 Pa.C.S. §§ 4551—4553 and 6103.

Source

The provisions of this § 171.80 adopted August 19, 1983, effective August 20, 1983, 13 Pa.B. 2561; readopted December 4, 1987, effective December 5, 1987, 17 Pa.B. 5052; amended May 20, 2005, effective May 21, 2005, 35 Pa.B. 3039. Immediately preceding text appears at serial page (219646).

§ 171.81. Wiring.

Wiring shall conform to the following:

- (1) Wiring shall conform to current applicable recommended practices of SAE Standard J1292. See Appendix A.
- (2) Circuits shall conform to the following specifications:
 - (i) Wiring shall be arranged in at least six regular circuits, as follows:
 - (A) Head, tail, stop (brake) and instrument panel lamps.
 - (B) Clearance, side-marker and stepwell lamps-step well lamp shall be actuated when service door is opened.
 - (C) Dome lamps.
 - (D) Ignition and emergency door signal.
 - (E) Turn signal lamps and hazard warning switch.
 - (F) Alternately flashing signal lamps.
 - (ii) Each circuit shall be protected by a fuse, circuit breaker or multiplex electrical circuit technology. A system of color coding shall be used.
 - (iii) A combination circuits listed in this paragraph may be subdivided into additional independent circuits.
 - (iv) At least one additional circuit shall be installed for heaters and defrosters.
 - (v) Whenever possible, other electrical functions, such as sanders and electric-type windshield wipers, shall be provided with independent and properly protected circuits.
 - (vi) Each body circuit shall be coded by number or letter on a diagram of circuits and shall be attached to the body in a readily accessible location.

(3) The entire electrical system of the body shall be designed for the same voltage as the chassis on which the body is mounted.

(4) A body wiring diagram of easy readable size shall be furnished or affixed in an area convenient to the electrical accessory control panel.

(5) Wiring shall have an amperage capacity equal to or exceeding the designed load. Wiring splices shall be done at an accessible location and noted as splices on the wiring diagram.

(6) Body power wire shall be attached to a special terminal on the chassis.

(7) Wires passing through metal openings shall be protected by grommets.

(8) Wires not enclosed within the body shall be fastened securely at intervals of not more than 18 inches. Joints shall be soldered or joined by equally effective connectors.

Authority

The provisions of this § 171.81 amended under the Vehicle Code, 75 Pa.C.S. §§ 4551—4553 and 6103.

Source

The provisions of this § 171.81 adopted August 19, 1983, effective August 20, 1983, 13 Pa.B. 2561; readopted December 4, 1987, effective December 5, 1987, 17 Pa.B. 5052; amended May 20, 2005, effective May 21, 2005, 35 Pa.B. 3039. Immediately preceding text appears at serial pages (219646) to (219647).

§ 171.82. Backup alarm.

An automatic audible backup alarm, if used, shall be installed behind the rear axle. The backup alarm shall comply with SAE Standard J994b. See Appendix A.

Authority

The provisions of this § 171.82 issued under the Vehicle Code, 75 Pa.C.S. §§ 4103, 4551—4553 and 6103.

Source

The provisions of this § 171.82 adopted September 13, 1996, effective September 14, 1996, 26 Pa.B. 4411.

§ 171.83. Portable emergency warning devices.

Every bus shall carry at least three portable emergency reflective triangles, as specified by Chapter 167 (relating to portable emergency warning devices). They shall be mounted in an accessible place in the driver's compartment.

Authority

The provisions of this § 171.83 issued under the Vehicle Code, 75 Pa.C.S. §§ 4103, 4551—4553 and 6103.

Source

The provisions of this § 171.83 adopted September 13, 1996, effective September 14, 1996, 26 Pa.B. 4411; amended May 20, 2005, effective May 21, 2005, 35 Pa.B. 3039. Immediately preceding text appears at serial page (219647).

§ 171.84. Additional equipment items.

Equipment added and alterations made to a school bus after its manufacture shall meet applicable Federal test standards. Additional equipment items not specifically required by Federal standards, 75 Pa.C.S. §§ 101—9821 (relating to the Vehicle Code) or Department-promulgated regulations for vehicles, equipment and devices installed on or in a school bus shall bear the trademark, name or code symbol under which it is approved. Installed additional equipment may not interfere with or violate any equipment standard or requirement. Equipment items not specifically required by law or regulation may not replace or interfere with a required equipment item.

Authority

The provisions of this § 171.84 issued under the Vehicle Code, 75 Pa.C.S. §§ 4103, 4551—4553 and 6103.

Source

The provisions of this § 171.84 adopted September 13, 1996, effective September 14, 1996, 26 Pa.B. 4411.

§ 171.85. Video equipment.

Installation of video equipment is at the discretion of the school district or the school bus contractor.

Authority

The provisions of this § 171.85 issued under the Vehicle Code, 75 Pa.C.S. §§ 4551—4553 and 6103.

Source

The provisions of this § 171.85 adopted May 20, 2005, effective May 21, 2005, 35 Pa.B. 3039.

§ 171.86. Fire axe.

Fire axes are prohibited.

Authority

The provisions of this § 171.86 issued under the Vehicle Code, 75 Pa.C.S. §§ 4551—4553 and 6103.

Source

The provisions of this § 171.86 adopted May 20, 2005, effective May 21, 2005, 35 Pa.B. 3039.

**Subchapter D. ADDITIONAL STANDARDS FOR SPECIALLY
EQUIPPED SCHOOL BUSES AND SCHOOL VEHICLES**

Sec.

- 171.91. General requirement.
- 171.92. Aisles.
- 171.93. Securement devices and safety restraints.
- 171.94. Grab handles.
- 171.95. Heaters.
- 171.96. Power lift.
- 171.97. Ramps.
- 171.98. Regular service entrance.
- 171.99. Restraining devices.
- 171.101. Seating arrangements.
- 171.102. Special light.
- 171.103. Special service entrance.
- 171.104. Special service entrance doors.
- 171.105. Identification.
- 171.106. Powerlift uprights, barriers and chain on elevator-type lifts through the floor.
- 171.107. Web cutter.

Cross References

This subchapter cited in 22 Pa. Code § 59.41 (relating to school buses/vehicles); and 67 Pa. Code § 171.2 (relating to definitions).

§ 171.91. General requirement.

School buses used for transporting students with disabilities shall comply with Subchapters B, C, G and this subchapter. School vehicles used for the transportation of students with disabilities shall comply with Subchapter E (relating to school vehicle standards) and this subchapter.

Authority

The provisions of this § 171.91 amended under the Vehicle Code, 75 Pa.C.S. §§ 4103, 4551—4553 and 6103.

Source

The provisions of this § 171.91 adopted August 19, 1983, effective August 20, 1983, 13 Pa.B. 2561; readopted December 4, 1987, effective December 5, 1987, 17 Pa.B. 5052; amended September 13, 1996, effective September 14, 1996, 26 Pa.B. 4411; amended May 20, 2005, effective May 21, 2005, 35 Pa.B. 3039. Immediately preceding text appears at serial pages (219648) to (219649).

§ 171.92. Aisles.

(a) School buses equipped with a power lift or a ramp shall have aisles a minimum of 30 inches wide leading from the wheelchair or other type of mobility device area to the emergency door, power lift or ramp special service entrance. Under § 171.42 (relating to aisle), school buses that are not equipped with a power lift or ramp shall have aisles with a minimum clearance of at least 30 centimeters—11 3/4 inches—wide leading to the emergency door and the service entrance door.

(b) School vehicles may not be equipped with more than two wheelchair positions. (Each wheelchair seating position is counted as four designated seating positions, under 49 CFR 571.3(b) (relating to definitions)).

Authority

The provisions of this § 171.92 amended under the Vehicle Code, 75 Pa.C.S. §§ 4103, 4551—4553 and 6103.

Source

The provisions of this § 171.92 adopted August 19, 1983, effective August 20, 1983, 13 Pa.B. 2561; readopted December 4, 1987, effective December 5, 1987, 17 Pa.B. 5052; amended September 13, 1996, effective September 14, 1996, 26 Pa.B. 4411; amended May 20, 2005, effective May 21, 2005, 35 Pa.B. 3039. Immediately preceding text appears at serial page (219649).

§ 171.93. Securement devices and safety restraints.

The requirements for securement devices and safety restraints are as follows:

- (1) Each wheelchair or other type of mobility device location shall have devices that secure wheelchairs or other types of mobility devices in a forward-facing position at a minimum of four anchorage points. The securement devices shall be installed and used as designated by the manufacturer.
- (2) Three-point safety restraints for lap and upper torso shall be provided for wheelchair and other types of mobility device occupants.
- (3) Securement devices and safety restraints shall be designed and installed in compliance with FMVSS No. 222. See Appendix A.

Authority

The provisions of this § 171.93 amended under the Vehicle Code, 75 Pa.C.S. §§ 4103, 4551—4553 and 6103.

Source

The provisions of this § 171.93 adopted August 19, 1983, effective August 20, 1983, 13 Pa.B. 2561; readopted December 4, 1987, effective December 5, 1987, 17 Pa.B. 5052; amended September 13, 1996, effective September 14, 1996, 26 Pa.B. 4411. Immediately preceding text appears at serial page (129344).

§ 171.94. Grab handles.

Grab handles shall be provided on the interior of school buses on each side of the right front service door.

Authority

The provisions of this § 171.94 amended under the Vehicle Code, 75 Pa.C.S. §§ 4551—4553 and 6103.

Source

The provisions of this § 171.94 adopted August 19, 1983, effective August 20, 1983, 13 Pa.B. 2561; readopted December 4, 1987, effective December 5, 1987, 17 Pa.B. 5052; amended May 20, 2005, effective May 21, 2005, 35 Pa.B. 3039. Immediately preceding text appears at serial pages (219649) to (219650).

§ 171.95. Heaters.

Additional heaters may be installed in the rear portion of a school bus.

Authority

The provisions of this § 171.95 amended under the Vehicle Code, 75 Pa.C.S. §§ 4551—4553 and 6103.

Source

The provisions of this § 171.95 adopted August 19, 1983, effective August 20, 1983, 13 Pa.B. 2561; readopted December 4, 1987, effective December 5, 1987, 17 Pa.B. 5052; amended May 20, 2005, effective May 21, 2005, 35 Pa.B. 3039. Immediately preceding text appears at serial page (219650).

§ 171.96. Power lift.

(a) *General.* A school bus or school vehicle that is used specifically for the transportation of school children who utilize wheelchairs or other types of mobility devices, or who require life support equipment which cannot use the regular service entrance shall be equipped with a power lift. A power lift system shall comply and be installed in accordance with any applicable FMVSS. If a power lift system is inadequate to load or unload school children having special or unique needs, a ramp device may be installed.

(b) *Specific requirements.* The requirements for power lifts are as follows:

(1) The power lift shall be located either in the rear or on the right side of the vehicle body, but confined within the perimeter of the vehicle body when not extended. The power lift may not be attached to the exterior sides of the vehicle.

(2) The lifting mechanism shall be able to lift a minimum pay load of 800 pounds. A clear opening and platform to accommodate a 30-inch wide wheelchair shall be provided.

(3) When the platform is in the fully up position, it shall be locked in position mechanically by means other than a support or lug in the door.

(4) Controls shall be provided that enable the operator to activate the lift mechanism from either inside or outside of the school bus. There shall be a means of preventing the lift platform from falling while in operation due to a power failure.

(5) Power lifts shall be equipped so they may be manually operated in the event of a power failure.

(6) The lift travel shall allow the lift platform to rest securely on the ground.

(7) Edges of the platform shall be designed to prevent the wheelchair or other type of mobility device from slipping or rolling off the platform and to prevent the operator's feet from being entangled during the raising and lowering process.

(8) A self-adjusting, skid resistant plate shall be installed on the outer edge of the platform to minimize the incline from the lift platform to the ground level.

(9) A circuit breaker, fuse or an electronic device which provides protection against short circuits, thermal overloads and reversed polarity shall be installed between the power source and the lift motor, if electrical power is used.

(10) The lift mechanism shall be designed to prevent excessive pressure from building in the hydraulic system when the platform reaches the full up or full down position.

Authority

The provisions of this § 171.96 amended under the Vehicle Code, 75 Pa.C.S. §§ 4103, 4551—4553 and 6103.

Source

The provisions of this § 171.96 adopted August 19, 1983, effective August 20, 1983, 13 Pa.B. 2561; readopted December 4, 1987, effective December 5, 1987, 17 Pa.B. 5052; amended September 13, 1996, effective September 14, 1996, 26 Pa.B. 4411; amended May 20, 2005, effective May 21, 2005, 35 Pa.B. 3039. Immediately preceding text appears at serial pages (219650) to (219651).

§ 171.97. Ramps.

(a) *General.* If a power lift system is inadequate to load and unload students having special or unique needs, a ramp device may be installed.

(b) *Requirements.* The requirements for ramps are as follows:

(1) Ramps shall be rigid and of sufficient strength to support the wheel chair or other type of mobility device, occupant and attendants without stress damage.

(2) Ramps shall be equipped with a protective flange on each longitudinal side to keep wheel chairs or other types of mobility devices on the ramp.

(3) Ramp floors shall be of a nonskid material.

(4) Ramps shall be equipped with a handle and constructed so as to permit one person to put the ramp in place and return it to its storage place.

(5) Ramps, during use, shall be connected to the school bus or school vehicle at floor level to permit easy access of wheel chairs or other types of mobility devices, and to be free of danger of detachment.

(6) A dustproof and waterproof enclosed container shall be provided if the ramp is stored under the floor.

Authority

The provisions of this § 171.97 amended under the Vehicle Code, 75 Pa.C.S. §§ 4103, 4551—4553 and 6103.

Source

The provisions of this § 171.97 adopted August 19, 1983, effective August 20, 1983, 13 Pa.B. 2561; readopted December 4, 1987, effective December 5, 1987, 17 Pa.B. 5052; amended September 13, 1996, effective September 14, 1996, 26 Pa.B. 4411; amended May 20, 2005, effective May 21, 2005, 35 Pa.B. 3039. Immediately preceding text appears at serial page (219651).

§ 171.98. Regular service entrance.

An additional foldout step may be provided to make the step level no more than 6 inches above the ground.

Authority

The provisions of this § 171.98 amended under the Vehicle Code, 75 Pa.C.S. §§ 4103, 4551—4553 and 6103.

Source

The provisions of this § 171.98 adopted August 19, 1983, effective August 20, 1983, 13 Pa.B. 2561; readopted December 4, 1987, effective December 5, 1987, 17 Pa.B. 5052; amended September 13, 1996, effective September 14, 1996, 26 Pa.B. 4411. Immediately preceding text appears at serial page (122812).

§ 171.99. Restraining devices.

(a) Seat frames and seats may be equipped with belt restraint systems designed and installed in accordance with FMVSS Nos. 209 and 213 and used as designated by the manufacturer. Attachment framework and anchorage devices shall conform with FMVSS No. 210—See Appendix A.

(b) Drivers of school vehicles are required to comply with the requirements of 75 Pa.C.S. § 4581 (relating to child passenger restraints) and the Department's regulations implementing those requirements.

Authority

The provisions of this § 171.99 amended under the Vehicle Code, 75 Pa.C.S. §§ 4103, 4551—4553 and 6103.

Source

The provisions of this § 171.99 adopted August 19, 1983, effective August 20, 1983, 13 Pa.B. 2561; readopted December 4, 1987, effective December 5, 1987, 17 Pa.B. 5052; amended September 13, 1996, effective September 14, 1996, 26 Pa.B. 4411; amended May 20, 2005, effective May 21, 2005, 35 Pa.B. 3039. Immediately preceding text appears at serial page (219652).

§ 171.101. Seating arrangements.

Seating shall be forward-facing.

Authority

The provisions of this § 171.101 amended under the Vehicle Code, 75 Pa.C.S. §§ 4103, 4551—4553 and 6103.

Source

The provisions of this § 171.101 adopted August 19, 1983, effective August 20, 1983, 13 Pa.B. 2561; readopted December 4, 1987, effective December 5, 1987, 17 Pa.B. 5052; amended September 13, 1996, effective September 14, 1996, 26 Pa.B. 4411. Immediately preceding text appears at serial page (122813).

§ 171.102. Special light.

Lights shall be placed inside the school bus or school vehicle to sufficiently illuminate the lift area and shall be activated from the door area.

Authority

The provisions of this § 171.102 amended under the Vehicle Code, 75 Pa.C.S. §§ 4551—4553 and 6103.

Source

The provisions of this § 171.102 adopted August 19, 1983, effective August 20, 1983, 13 Pa.B. 2561; readopted December 4, 1987, effective December 5, 1987, 17 Pa.B. 5052; amended May 20, 2005, effective May 21, 2005, 35 Pa.B. 3039. Immediately preceding text appears at serial pages (219652) and (301841).

§ 171.103. Special service entrance.

(a) *General.* A special service entrance may be constructed to accommodate a wheelchair lift for the loading and unloading of passengers.

(b) *Requirements for school buses.* The following apply to the special service entrance on school buses:

(1) The special service entrance shall be located at a convenient point on the right—curb side—of the school bus and far enough to the rear to prevent the door, when open, from obstructing the right front service door—excluding a regular front service door lift.

(2) The opening may extend below the floor through the bottom of the body skirt. If such an opening is used, reinforcements shall be installed at the front and rear of the floor opening to support the floor and provide the same strength as other floor openings.

(3) With doors open, the minimum clear opening shall be 30 inches in width.

(4) A drip moulding shall be installed above the opening to effectively divert water from the entrance.

(5) The entrance shall be of sufficient width and depth to accommodate various mechanical lifts and related accessories as well as the lifting platform.

(6) Door posts and headers from the entrance shall be reinforced sufficiently to provide support and strength equivalent to the areas of the side of the school bus not used for service doors.

(c) *Requirements for school vehicles.* The following apply to the special service entrance on school vehicles:

(1) The special service entrance shall be located at a convenient point to the right—curb side or to the rear of the school vehicle.

(2) With doors open, the minimum clear opening shall be 30 inches in width.

(3) A drip molding shall be installed above the opening to effectively divert water from the entrance.

(4) The entrance shall be of sufficient width and depth to accommodate the mechanical lift and related accessories as well as the lifting platform.

(5) Door posts and headers from the entrance shall be reinforced sufficiently to provide support and strength equivalent to original manufacture.

Authority

The provisions of this § 171.103 amended under the Vehicle Code, 75 Pa.C.S. §§ 4551—4553 and 6103.

Source

The provisions of this § 171.103 adopted August 19, 1983, effective August 20, 1983, 13 Pa.B. 2561; readopted December 4, 1987, effective December 5, 1987, 17 Pa.B. 5052; amended May 20, 2005, effective May 21, 2005, 35 Pa.B. 3039. Immediately preceding text appears at serial page (301841).

§ 171.104. Special service entrance doors.

The requirements for special service entrance doors are as follows:

(1) Either a single door or double doors may be used for the special service entrance.

(2) Doors shall open outwardly.

(3) Doors shall have positive fastening devices to hold the doors in the open position.

(4) Doors shall be weather sealed. Double doors shall be so constructed that a flange on the outside of the forward door overlaps the edge of the rear door when closed.

(5) If optional power doors are installed, the design shall permit release of the doors for opening and closing from inside the school bus or school vehicle.

(6) If manually operated dual doors are provided, the rear door shall have at least a one point fastening device to the header.

(i) The forward mounted door shall have at least three fastening devices—one to the header, one to the floor line of the body and the other into the rear door.

(ii) These locking devices shall afford maximum safety when the doors are in the closed position.

(iii) The door and hinge mechanism shall be of sufficient strength to provide for the same type of use as a standard entrance door.

(7) Door materials, panels and structural strength shall be equivalent to the conventional service and emergency doors. Color, rub rail extensions, lettering and other exterior features shall match adjacent sections of the body.

(8) Each door shall have windows set in rubber compatible within 1 inch of the lower line of the adjacent sash.

(9) Doors shall be equipped with a device that will actuate an audible or visible signal located in the driver's compartment when the doors are not securely closed and the ignition is in the "on" position.

(10) The lifting mechanism switch shall be wired so as to prevent the lifting mechanism from operating when the lift platform door is closed.

(11) Supplemental security locks installed on special service entrance doors shall be equipped with an ignition interlock system or an audiovisual alarm located in the driver's compartment.

Authority

The provisions of this § 171.104 amended under the Vehicle Code, 75 Pa.C.S. §§ 4103, 4551—4553 and 6103.

Source

The provisions of this § 171.104 adopted August 19, 1983, effective August 20, 1983, 13 Pa.B. 2561; readopted December 4, 1987, effective December 5, 1987, 17 Pa.B. 5052; amended September 13, 1996, effective September 14, 1996, 26 Pa.B. 4411; amended November 26, 2003, effective November 29, 2003, 33 Pa.B. 5817; amended May 20, 2005, effective May 21, 2005, 35 Pa.B. 3039. Immediately preceding text appears at serial pages (301841) to (301842).

§ 171.105. Identification.

A specially equipped school bus or school vehicle may display the universal handicapped symbol on the rear of the vehicle below the window line. The emblem shall be white on blue, may not exceed 12 inches in height and width, and shall be of reflective material.

Authority

The provisions of this § 171.105 issued under the Vehicle Code, 75 Pa.C.S. §§ 4103, 4551—4553 and 6103.

Source

The provisions of this § 171.105 adopted September 13, 1996, effective September 14, 1996, 26 Pa.B. 4411; amended May 20, 2005, effective May 21, 2005, 35 Pa.B. 3039. Immediately preceding text appears at serial pages (301842) to (301843).

§ 171.106. Power lift uprights, barriers and chain on elevator-type lifts through the floor.

(a) Heavy-duty padded panels shall extend above floor level on the nonentrance and nonexit sides of the special service opening to prevent school children from falling into the lift opening when the lift is lowered. The width of the panels shall be equal to the depth of the floor opening.

(b) A covered chain shall be fastened to the rear panel with a hook and eye fastener for attachment to the forward panel.

(c) A padded barrier shall be placed in front of all forward-facing passenger seats that do not have another seat in front of them, as required by FMVSS No. 222. See Appendix A.

Authority

The provisions of this § 171.106 issued under the Vehicle Code, 75 Pa.C.S. §§ 4103, 4551—4553 and 6103.

Source

The provisions of this § 171.106 adopted September 13, 1996, effective September 14, 1996, 26 Pa.B. 4411.

§ 171.107. Web cutter.

Every specially equipped school bus and school vehicle shall have at least one web cutter securely mounted in a visible location within the driver's compartment.

Authority

The provisions of this § 171.107 issued under the Vehicle Code, 75 Pa.C.S. §§ 4551—4553 and 6103.

Source

The provisions of this § 171.107 adopted May 20, 2005, effective May 21, 2005, 35 Pa.B. 3039.

Subchapter E. SCHOOL VEHICLE STANDARDS

Sec.

- 171.121. Applicability.
- 171.122. Fire extinguisher.
- 171.123. First aid.
- 171.124. Identification.
- 171.125. Seating.
- 171.126. Web cutter.
- 171.127. Certification.

Cross References

This subchapter cited in 67 Pa. Code § 171.91 (relating to general requirement).

§ 171.121. Applicability.

The requirements of this subchapter apply to motor vehicles used to transport preprimary, primary or secondary school students to or from public, private or parochial schools or events related to these schools or school-related activities, which are designed to carry 11 to 15 passengers, including the driver, and which are registered in this Commonwealth as a bus prior to March 1, 1993, or a motor vehicle which is designed to carry 11 to 15 passengers, including the driver, and which was titled to any public, private or parochial school on or before March 1, 1993, and which is registered to that public, private or parochial school in this Commonwealth as a bus prior to September 15, 1993 and school vehicles.

Authority

The provisions of this § 171.121 amended under the Vehicle Code, 75 Pa.C.S. §§ 4103, 4551—4553 and 6103.

Source

The provisions of this § 171.121 adopted August 19, 1983, effective August 20, 1983, 13 Pa.B. 2561; readopted December 4, 1987, effective December 5, 1987, 17 Pa.B. 5052; amended September 13, 1996, effective September 14, 1996, 26 Pa.B. 4411; amended May 20, 2005, effective May 21, 2005, 35 Pa.B. 3039. Immediately preceding text appears at serial pages (301843) to (301844).

Cross References

This section cited in 67 Pa. Code § 171.122 (relating to fire extinguisher); and 67 Pa. Code § 171.124 (relating to identification).

§ 171.122. Fire extinguisher.

(a) *Required.* Every school vehicle and every motor vehicle described in § 171.121 (relating to applicability) shall be equipped with at least one pressurized, multi-purpose, dry chemical or halogenated agent fire extinguisher, mounted in a bracket readily accessible to the driver. The fire extinguisher shall be mounted as directed by the manufacturer. The fire extinguisher shall have a hose and nozzle and be in good and usable condition. A pressure gauge shall be mounted on the extinguisher so as to be easily read without removing the extinguisher from its mounted position.

(b) *Type.* The fire extinguisher shall be of a type meeting the Underwriter Laboratories, Inc. Standard 299 or 1093—See Appendix A—with a total rating of not less than 2 A-10 BC. The operating mechanism shall be sealed with a type of seal which will not interfere with the use of the fire extinguisher.

Authority

The provisions of this § 171.122 amended under the Vehicle Code, 75 Pa.C.S. §§ 4103, 4551—4553 and 6103.

Source

The provisions of this § 171.122 adopted August 19, 1983, effective August 20, 1983, 13 Pa.B. 2561; readopted December 4, 1987, effective December 5, 1987, 17 Pa.B. 5052; amended September 13, 1996, effective September 14, 1996, 26 Pa.B. 4411. Immediately preceding text appears at serial page (122815).

§ 171.123. First aid.

(a) *Required.* Every vehicle shall have a removable moisture and dustproof first aid kit mounted in an accessible place within the driver's compartment. The first aid kit shall be mounted as directed by the manufacturer. The first aid kit shall be labeled and securely placed or mounted in an easily accessible location.

(b) *Content.* The first aid kit shall contain, at a minimum, the following items:

- (1) One 1 inch × 2 1/2 yards rolls of nonlatex adhesive tape.
- (2) One package sterile gauze pads, 3 inches × 3 inches.
- (3) One package 3/4 inch × 3 inches adhesive bandages.
- (4) One package 2 inch bandage compresses.
- (5) One package 3 inch bandage compresses.
- (6) One 2 inch × 6 yards sterile gauze roller bandage.
- (7) One nonsterile triangular bandage approximately 40 inches × 36 inches × 54 inches with two safety pins.
- (8) One package sterile gauze pads, 36 inches x 36 inches (U.S.P. 2423 count).
- (9) One sterile eye pad.
- (10) One pair rounded end scissors.

(c) *Body fluid clean-up kit.* Every vehicle shall have a removable and moisture proof body fluid clean-up kit. It shall be securely placed or mounted in an easily accessible location and labeled as a body fluid clean-up kit.

(d) *Surgical gloves and mouth barriers.* Either the first aid kit or the body fluid cleanup kit shall contain:

- (1) One pair of nonlatex surgical gloves.
- (2) One mouth barrier.

Authority

The provisions of this § 171.123 amended under the Vehicle Code, 75 Pa.C.S. §§ 4103, 4551—4553 and 6103.

Source

The provisions of this § 171.123 adopted August 19, 1983, effective August 20, 1983, 13 Pa.B. 2561; readopted December 4, 1987, effective December 5, 1987, 17 Pa.B. 5052; amended September 13, 1996, effective September 14, 1996, 26 Pa.B. 4411; amended November 26, 2003, effective November 29, 2003, 33 Pa.B. 5817. Immediately preceding text appears at serial pages (219656) to (219657).

§ 171.124. Identification.

(a) *Required.* Every school vehicle and every motor vehicle described in § 171.121 (relating to applicability) shall bear the words, “School Students,” in black letters at least 6 inches in height on a background of National School Bus Yellow—see Appendix B—on two separate signs attached to the front and rear of the vehicle or on one two-sided sign located approximately in the center of the vehicle and visible from both the front and rear. Signs shall be a minimum of 44 inches long mounted in a horizontal position and clearly visible to oncoming vehicles. Front and rear mounted signs shall be mounted at a height of not less than 12 inches from the ground measuring from the bottom of the sign and securely fastened to prevent the sign from swinging. When space permits, signs may be painted on the vehicle in a straight line as high as possible. Decals or magnetic signs are permitted. Lettering shall conform to Series B of Standard Alphabets for Highway Signs.

(b) *Additional markings.* School vehicles and motor vehicles described in § 171.121 shall have the name of the school district, contractor’s name, or private or parochial school, lettered on each side of the body in letters of not less than 2 inches in height and not more than 4 inches in height. Decals are permitted.

Authority

The provisions of this § 171.124 amended under the Vehicle Code, 75 Pa.C.S. §§ 4103, 4551—4553 and 6103.

Source

The provisions of this § 171.124 adopted August 19, 1983, effective August 20, 1983, 13 Pa.B. 2561; readopted December 4, 1987, effective December 5, 1987, 17 Pa.B. 5052; amended September 13, 1996, effective September 14, 1996, except subsection (b) effective September 15, 1997, 26 Pa.B. 4411. Immediately preceding text appears at serial page (122816).

§ 171.125. Seating.

(a) *Vehicle seats.* Vehicle seats and seat belts shall be of a type and installed as recommended by the vehicle manufacturer.

(b) *Dividers.* Dividers may not be used to separate the seats.

(c) *Seating space.* A designated seating position of safe design and construction shall be provided for each passenger and a passenger may not be carried for which a safe designated seating position is not available. Seats shall be forward facing.

(d) *Child passenger restraints.* Drivers of school vehicles are required to comply with the requirements of 75 Pa.C.S. § 4581 (relating to child passenger restraints) and the Department’s regulations implementing those requirements.

Authority

The provisions of this § 171.125 amended under the Vehicle Code, 75 Pa.C.S. §§ 4103, 4551—4553 and 6103.

Source

The provisions of this § 171.125 adopted August 19, 1983, effective August 20, 1983, 13 Pa.B. 2561; readopted December 4, 1987, effective December 5, 1987, 17 Pa.B. 5052; amended September 13, 1996, effective September 14, 1996, 26 Pa.B. 4411; amended May 20, 2005, effective May 21, 2005, 35 Pa.B. 3039. Immediately preceding text appears at serial page (301846).

§ 171.126. Web cutter.

Every school vehicle shall have at least one web cutter securely mounted in a visible location within the driver's compartment.

Authority

The provisions of this § 171.126 issued under the Vehicle Code, 75 Pa.C.S. §§ 4551—4553 and 6103.

Source

The provisions of this § 171.126 adopted May 20, 2005, effective May 21, 2005, 35 Pa.B. 3039.

§ 171.127. Certification.

A school vehicle shall be certified by the original manufacturer or final stage manufacturer to meet the Federal Motor Vehicle Safety Standards for a passenger car or a multipurpose passenger vehicle.

Authority

The provisions of this § 171.127 issued under the Vehicle Code, 75 Pa.C.S. §§ 4551—4553 and 6103.

Source

The provisions of this § 171.127 adopted May 20, 2005, effective May 21, 2005, 35 Pa.B. 3039.

**Subchapter F. MASS TRANSIT PUPIL TRANSPORTATION
BUS STANDARDS****Sec.**

- 171.131. Applicability.
- 171.132. Fire extinguisher.
- 171.133. First aid.
- 171.134. Identification.
- 171.135. Mirrors.
- 171.136. Signal lamps.
- 171.137. Doors.
- 171.138. Portable emergency warning device.
- 171.139. Seating.

§ 171.131. Applicability.

This subchapter applies to mass transit pupil transportation buses.

Source

The provisions of this § 171.131 adopted August 19, 1983, effective August 20, 1983, 13 Pa.B. 2561; readopted December 4, 1987, effective December 5, 1987, 17 Pa.B. 5052. Immediately preceding text appears at serial page (83763).

§ 171.132. Fire extinguisher.

(a) *Required.* Every mass transit pupil transportation bus shall be equipped with at least one pressurized, multipurpose, dry chemical or halogenated agent fire extinguisher, mounted in a bracket in the driver's compartment and readily

accessible to the driver. The fire extinguisher shall be mounted as directed by the manufacturer. The fire extinguisher shall have a hose and nozzle and be in good and usable condition. A pressure gauge shall be mounted on the extinguisher so as to be easily read without removing the extinguisher from its mounted position.

(b) *Type.* The fire extinguisher shall be of a type meeting the Underwriter Laboratories, Inc. Standard 299 or 1093—See Appendix A—with a total rating of not less than 2 A-10 BC. The operating mechanism shall be sealed with a type of seal which will not interfere with the use of the fire extinguisher.

Authority

The provisions of this § 171.132 amended under the Vehicle Code, 75 Pa.C.S. §§ 4103, 4551—4553 and 6103.

Source

The provisions of this § 171.132 adopted August 19, 1983, effective August 20, 1983, 13 Pa.B. 2561; readopted December 4, 1987, effective December 5, 1987, 17 Pa.B. 5052; amended September 13, 1996, effective September 14, 1996, 26 Pa.B. 4411. Immediately preceding text appears at serial pages (122817) to (122818).

§ 171.133. First aid.

(a) *First aid kit.* Every mass transit pupil transportation bus shall have a removable moisture and dust proof first aid kit mounted in an accessible place within the driver's compartment. The first aid kit shall be mounted as directed by the manufacturer. The first aid kit shall be labeled and visible to the driver or its location shall be marked.

(b) *Content.* The first aid kit shall contain, at a minimum, the following items:

- (1) Two 1 inch × 2 1/2 yards rolls of nonlatex adhesive tape.
- (2) Twenty-four sterile gauze pads, 3 inches × 3 inches.
- (3) One hundred 3/4 inch × 3 inches adhesive bandages.
- (4) Eight 2 inch bandage compresses.
- (5) Ten 3 inch bandage compresses.
- (6) Two 2 inches × 6 yards sterile gauze roller bandages.
- (7) Two nonsterile triangular bandages approximately 40 inches × 36 inches × 54 inches with 2 safety pins.
- (8) Three sterile gauze pads, 36 inches × 36 inches.
- (9) Three sterile eye pads.
- (10) One pair rounded end scissors.

(c) *Body fluid clean-up kit.* Every mass transit pupil transportation bus shall have a removable and moisture proof body fluid clean-up kit. It shall be securely placed or mounted in an easily accessible location and labeled as a body fluid clean-up kit.

(d) *Surgical gloves and mouth barriers.* Either the first aid kit or the body fluid cleanup kit shall contain:

- (1) One pair of nonlatex surgical gloves.
- (2) One mouth barrier.

Authority

The provisions of this § 171.133 amended under the Vehicle Code, 75 Pa.C.S. §§ 4103, 4551—4553 and 6103.

Source

The provisions of this § 171.133 adopted August 19, 1983, effective August 20, 1983, 13 Pa.B. 2561; readopted December 4, 1987, effective December 5, 1987, 17 Pa.B. 5052; amended September 13, 1996, effective September 14, 1996, 26 Pa.B. 4411; amended November 26, 2003, effective November 29, 2003, 33 Pa.B. 5817. Immediately preceding text appears at serial pages (219659) to (219660).

§ 171.134. Identification.

A mass transit pupil transportation bus shall be equipped with temporary signs, located conspicuously on the front and rear of the vehicle.

- (1) The front sign shall have the words “**SCHOOL BUS**” printed in black letters not less than 8 inches high, on a background of National School Bus Yellow. See Appendix B.
- (2) The rear sign shall be at least 10 square feet in size and have the words “**SCHOOL BUS**” printed in black letters not less than 8 inches high on a background of National School Bus Yellow. See Appendix B.
- (3) The 8 inch letters shall be Series D as specified in the Standard Alphabets-Federal Highway Administration, 1966.
- (4) The temporary signs shall be removed or covered when the bus is being used other than for the exclusive transportation of school children.

Source

The provisions of this § 171.134 adopted August 19, 1983, effective August 20, 1983, 13 Pa.B. 2561; readopted December 4, 1987, effective December 5, 1987, 17 Pa.B. 5052. Immediately preceding text appears at serial page (83764).

§ 171.135. Mirrors.

A mass transit pupil transportation bus shall be equipped with a system of mirrors that gives the seated driver a view of the roadway to each side of the bus and the area immediately in front of the front bumper, so that when a rod 30 inches long is placed upright on the ground at a point along a traverse line 1 foot forward of the forwardmost point of the bus and extending the width of the bus, at least 7-1/2 inches of the length of the rod shall be visible to the driver either by direct view or by means of an indirect visibility system.

Source

The provisions of this § 171.135 adopted August 19, 1983, effective August 20, 1983, 13 Pa.B. 2561; readopted December 4, 1987, effective December 5, 1987, 17 Pa.B. 5052. Immediately preceding text appears at serial page (83764).

§ 171.136. Signal lamps.

(a) *Required.* Except as provided in subsection (b), a mass transit pupil transportation bus shall be equipped with four red signal lamps and four amber signal lamps in accordance with § 171.59(b) (relating to lamps and signals).

(b) *Exceptions.* A mass transit pupil transportation bus need not be equipped with the signal lamps required by subsection (a) if it makes stops only at any of the following:

(1) On streets in urban districts designated by the Department or local authorities as streets on which the use of signal lamps is prohibited.

(2) At intersections or other places where traffic is controlled by uniformed police officers or appropriately attired persons authorized to direct, control or regulate traffic.

(3) In school bus loading areas designated by the Department or local authorities, if the bus is entirely off the roadway.

(c) *Limitations on use.* The signal lamps required by subsection (a) may not be activated when the bus is being used other than for the exclusive transportation of children to and from school and school related activities.

Source

The provisions of this § 171.136 adopted August 19, 1983, effective August 20, 1983, 13 Pa.B. 2561; readopted December 4, 1987, effective December 5, 1987, 17 Pa.B. 5052. Immediately preceding text appears at serial page (83765).

§ 171.137. Doors.

Supplemental security locks installed on doors shall be equipped with an ignition system or an audiovisual alarm located in the driver's compartment.

Authority

The provisions of this § 171.137 issued under the Vehicle Code, 75 Pa.C.S. §§ 4103, 4551—4553 and 6103.

Source

The provisions of this § 171.137 adopted September 13, 1996, effective September 14, 1996, 26 Pa.B. 4411.

§ 171.138. Portable emergency warning device.

Every bus shall carry at least three portable emergency reflective triangles, as specified by Chapter 167 (relating to portable emergency warning devices). They shall be mounted in an accessible place in the driver's compartment.

Authority

The provisions of this § 171.138 issued under the Vehicle Code, 75 Pa.C.S. §§ 4103, 4551—4553 and 6103.

Source

The provisions of this § 171.138 adopted September 13, 1996, effective September 14, 1996, 26 Pa.B. 4411; amended May 20, 2005, effective May 21, 2005, 35 Pa.B. 3039. Immediately preceding text appears at serial page (219662).

§ 171.139. Seating.

When used as a school bus, a mass transit pupil transportation bus shall provide designated seating positions of safe design and construction for all school children. A school child may not be carried for which a safe designated seating position is not available.

Authority

The provisions of this § 171.139 issued under the Vehicle Code, 75 Pa.C.S. §§ 4103, 4551—4553 and 6103.

Source

The provisions of this § 171.139 adopted September 13, 1996, effective September 14, 1996, 26 Pa.B. 4411.

**Subchapter G. OPERATION STANDARDS FOR VEHICLES
SUBJECT TO THIS CHAPTER**

Sec.

- 171.141. Accident reports.
- 171.142. Cleanliness.
- 171.143. Identification concealment.
- 171.144. Seating.
- 171.145. Service.
- 171.146. Doors.
- 171.147. Fire extinguishers.
- 171.148. Safety checks.
- 171.149. Unsafe operations.
- 171.150. Use of portable emergency warning devices.

Cross References

This subchapter cited in 67 Pa. Code § 171.1 (relating to applicability); and 67 Pa. Code § 171.91 (relating to general requirement).

§ 171.141. Accident reports.

Within 24 hours of its occurrence, and in addition to the accident reporting requirements of 75 Pa.C.S. §§ 3741—3754 (relating to accidents and accident reports), the owner or operator of a vehicle subject to this chapter shall report an

accident involving the vehicle to the chief school administrator or authorized representative of the school district or private or parochial school by which he is employed or under contract. Within 5 days of the accident, the vehicle owner or operator shall submit a completed accident report on a form approved by the Department to the Department's Pupil Transportation Section.

Authority

The provisions of this § 171.141 amended under the Vehicle Code, 75 Pa.C.S. §§ 4103, 4551—4553 and 6103.

Source

The provisions of this § 171.141 adopted August 19, 1983, effective August 20, 1983, 13 Pa.B. 2561; readopted December 4, 1987, effective December 5, 1987, 17 Pa.B. 5052; amended September 13, 1996, effective September 14, 1996, 26 Pa.B. 4411. Immediately preceding text appears at serial page (122820).

§ 171.142. Cleanliness.

School buses and school vehicles shall be kept in a clean condition both inside and outside.

Source

The provisions of this § 171.142 adopted August 19, 1983, effective August 20, 1983, 13 Pa.B. 2561; readopted December 4, 1987, effective December 5, 1987, 17 Pa.B. 5052. Immediately preceding text appears at serial page (83766).

§ 171.143. Identification concealment.

When a vehicle subject to this chapter is being operated upon a highway for purposes other than the actual transportation of school children to or from school or in connection with school activities, the words "SCHOOL BUS" or "SCHOOL STUDENTS" shall be removed or covered. During this operation, flashing visual signals may not be actuated. The transportation of school children shall include driving the vehicle from the school, garage or other place of storage to the point where the first child is picked up, and from the place where the last child is discharged to the school, garage or other place of storage.

Authority

The provisions of this § 171.143 amended under the Vehicle Code, 75 Pa.C.S. §§ 4103, 4551—4553 and 6103.

Source

The provisions of this § 171.143 adopted August 19, 1983, effective August 20, 1983, 13 Pa.B. 2561; readopted December 4, 1987, effective December 5, 1987, 17 Pa.B. 5052; amended September 13, 1996, effective September 14, 1996, 26 Pa.B. 4411. Immediately preceding text appears at serial page (122821).

§ 171.144. Seating.

(a) *Aisle clearance.* Passengers in school buses may not be seated so as to encroach on the minimum aisle clearance required in § 171.42 (relating to aisle).

(b) *Seat belts.* Passengers and drivers in vehicles that are equipped with seat belts shall be required to wear them whenever the vehicle is in motion.

(c) *Passengers.* Passengers shall be seated prior to the vehicle being placed in motion.

(d) *Standees.* Standees are not permitted.

Authority

The provisions of this § 171.144 amended under the Vehicle Code, 75 Pa.C.S. §§ 4103, 4551—4553 and 6103.

Source

The provisions of this § 171.144 adopted August 19, 1983, effective August 20, 1983, 13 Pa.B. 2561; readopted December 4, 1987, effective December 5, 1987, 17 Pa.B. 5052; amended September 13, 1996, effective September 14, 1996, 26 Pa.B. 4411. Immediately preceding text appears at serial page (122821).

§ 171.145. Service.

School buses and school vehicles shall be serviced in accordance with the maintenance schedule recommended by the manufacturer of the school bus or school vehicle. A record of such maintenance shall be kept by the owner or operator.

Source

The provisions of this § 171.145 adopted August 19, 1983, effective August 20, 1983, 13 Pa.B. 2561; readopted December 4, 1987, effective December 5, 1987, 17 Pa.B. 5052. Immediately preceding text appears at serial page (83766).

§ 171.146. Doors.

Doors shall be closed securely while the vehicle is in motion. Security lock systems on vehicle doors shall be kept open whenever the vehicle is in motion.

Authority

The provisions of this § 171.146 issued under the Vehicle Code, 75 Pa.C.S. §§ 4103, 4551—4553 and 6103.

Source

The provisions of this § 171.146 adopted September 13, 1996, effective September 14, 1996, 26 Pa.B. 4411.

§ 171.147. Fire extinguishers.

Owners of vehicles subject to this chapter shall have the fire extinguishers in their vehicles inspected at least once a year to insure that the fire extinguishers are fully charged, properly filled and operable. Upon approval, the fire extinguisher shall be tagged, signed and dated.

Authority

The provisions of this § 171.147 issued under the Vehicle Code, 75 Pa.C.S. §§ 4103, 4551—4553 and 6103.

Source

The provisions of this § 171.147 adopted September 13, 1996, effective September 14, 1996, 26 Pa.B. 4411.

§ 171.148. Safety checks.

Vehicles subject to this chapter shall be subject to safety checks at the discretion of school administrators or police officers.

Authority

The provisions of this § 171.148 issued under the Vehicle Code, 75 Pa.C.S. §§ 4103, 4551—4553 and 6103.

Source

The provisions of this § 171.148 adopted September 13, 1996, effective September 14, 1996, 26 Pa.B. 4411.

§ 171.149. Unsafe operations.

(a) *General.* Vehicles subject to this chapter may not be operated in a condition that is likely to cause an accident or a breakdown of the vehicle.

(b) *Exemption.* A vehicle subject to this chapter discovered to be in an unsafe condition while being operated on the highway may be continued in operation only to the nearest place where repairs can safely be effected. The operation shall be conducted only if it is less hazardous to the public than to permit the vehicle to remain on the highway.

(c) *Securing loose items.* Any items stored by the driver shall be secured, so that the items do not interfere with the operation of the accelerator or brake pedal, impede the loading or unloading process or any other operational control for the safe operation of the vehicle.

Authority

The provisions of this § 171.149 issued under the Vehicle Code, 75 Pa.C.S. §§ 4103, 4551—4553 and 6103.

Source

The provisions of this § 171.149 adopted September 13, 1996, effective September 14, 1996, 26 Pa.B. 4411; amended May 20, 2005, effective May 21, 2005, 35 Pa.B. 3039. Immediately preceding text appears at serial page (219665).

§ 171.150. Use of portable emergency warning devices.

In accordance with 75 Pa.C.S. § 4530(b) (relating to portable emergency warning devices), when a bus is disabled or stopped for more than 10 minutes upon a highway, the driver shall display at least three portable warning devices. These portable warning devices shall be displayed as required by § 167.8 (relating to display).

Authority

The provisions of this § 171.150 issued under the Vehicle Code, 75 Pa.C.S. §§ 4103, 4551—4553 and 6103.

Source

The provisions of this § 171.150 adopted September 13, 1996, effective September 14, 1996, 26 Pa.B. 4411.

APPENDIX A

1. For a summary or other explanation of any Federal standard, write the Director, Office of the Federal Register, National Archives and Records Administration, Washington, D.C. 20408. The *Code of Federal Regulations* publication sales are handled exclusively by the Superintendent of Documents.

United States Government Printing Office
 Superintendent of Documents
 Washington, D.C. 20402

49 CFR 393	Parts and Accessories Necessary for Safe Operation
49 CFR 396	Inspection, Repair and Maintenance
49 CFR 567.7	Requirements for Persons Who Alter Certified Vehicles
49 CFR 568.8	Requirements For Persons Who Alter Certified Vehicles
49 CFR 569	Regrooved Tires
49 CFR 571	Federal Motor Vehicle Safety Standards (FMVSS)
Standard 108	Lamps, Reflective Devices and Associated Equipment
Standard 111	Rearview Mirrors
Standard 117	Retreaded Pneumatic Tires
Standard 119	New Pneumatic Tires For Vehicles Other Than Passenger Cars
Standard 120	Tire Selection And Rims For Motor Vehicles Other Than Passenger Cars
Standard 125	Warning Devices
Standard 131	School Bus Pedestrian Safety Devices
Standard 205	Glazing Materials
Standard 208	Occupant Crash Protection
Standard 209	Seat Belt Assemblies
Standard 210	Seat Belt Assembly Anchorages
Standard 213	Child Restraint Systems
Standard 217	Bus Emergency Exits and Window Retention and Release
Standard 222	School Bus Passenger Seating and Crash Protection
Standard 302	Flammability of Interior Materials
49 CFR 581	Bumper Standard

2. To order SAE handbooks or manuals or for additional SAE information, write:

171-75

Society of Automotive Engineers, Inc. (SAE)
400 Commonwealth Drive
Warrendale, PA 15096-0001
(412) 776-4970

Standard J20c	Coolant System Hoses
Standard J56	Electrical Generating System (Alternator Type) Performance Curve and Test Procedure
Standard J180b	Electrical Charging Systems for Construction and Industrial Machinery
Standard J186a	Supplemental High Mounted Stop and Rear Turn Signal Lamps
Standard J377	Performance of Vehicle Traffic Horns
Standard J381	Windshield Defrosting Systems Test Procedure—Trucks, Buses and Multipurpose Vehicles
Standard J382	Windshield Defrosting Systems Performance Requirements—Trucks, Buses and Multipurpose Vehicles
Standard J578	Color Specifications
Standard J887a	School Bus Red Signal Lamps
Standard J994b	Alarm Backup Electric Performance Test and Application
Standard J1100	Motor Vehicle Dimensions
Standard J1133	School Bus Stop Arm
Standard J1292	Automobile, Truck, Truck-Tractor, Trailer and Motor Coach Wiring

3. For additional SBMI information, write:

School Bus Manufacturers Institute (SBMI)
Division of Truck Body and Equipment Association
7508 Ben Avon Road
Bethesda, Maryland 20817
(301) 299-8441

Design Objectives Booklet, current edition

Standard 001 Standard Code for Testing and Rating Automotive Bus Hot
Water Heating and Ventilating Equipment

4. For additional Underwriters Laboratories, Inc. information:

171-76

Underwriters Laboratories, Inc.
333 Pfingsten Rd.
Northbrook, Illinois 60062
(312) 272-8800

Standard 299 Dry Chemical Fire Extinguishers
Standard 723 Tests for Surface Burning Characteristics of Building
Materials
Standard 1093 Halogenated Agent Fire Extinguishers

5. For additional U.S. Department of Commerce information, write:

United States Department of Commerce
14th and E Streets
Washington, DC 20230
Standard PS1-83 Construction and Industrial Plywood

6. For additional ASTM information, write:

American Society for Testing and Materials (ASTM)
1916 Race Street
Philadelphia, Pennsylvania 19103
(215) 299-5400
Standard B117 Standard Method of Salt Spray (Fog) Testing

7. For additional General Services Administration Specification and Consumer Information, write:

General Services Administration
Specification & Consumer Information
Distribution Center
Washington Navy Yard
Building 197
Washington, DC 20407

Federal Coating Compound, Bituminous, Solvent Type, Specification Underbody (for Motor Vehicles) TT-C-520b

8. For additional National Institute of Standards and Technology (NIST) information, write:

171-77

(311763) No. 369 Aug. 05

National Institute of Standards and Technology
Publications and Programs Inquiries
Building 101, Room E106
Gaithersburg, MD 20899
(301) 975-3052

Federal Standard Color 37038
No. 595a

Authority

The provisions of this Appendix A amended under the Vehicle Code, 75 Pa.C.S. §§ 4103, 4551—4553 and 6103.

Source

The provisions of this Appendix A adopted August 19, 1983, effective August 20, 1983, 13 Pa.B. 2561; readopted December 4, 1987, effective December 5, 1987, 17 Pa.B. 5052; amended September 13, 1996, effective September 14, 1996, 26 Pa.B. 4411. Immediately preceding text appears at serial pages (122822) and (132815).

Cross References

This appendix cited in 67 Pa. Code § 171.1 (relating to applicability); 67 Pa. Code § 171.15 (relating to bumper, front); 67 Pa. Code § 171.18 (relating to color); 67 Pa. Code § 171.20 (relating to electrical system); 67 Pa. Code § 171.23 (relating to frame); 67 Pa. Code § 171.24 (relating to fuel system); 67 Pa. Code § 171.26 (relating to heating system); 67 Pa. Code § 171.28 (relating to instruments and instrument panel); 67 Pa. Code § 171.36 (relating to tires and rims); 67 Pa. Code § 171.38 (relating to undercoating); 67 Pa. Code § 171.44 (relating to bumper, rear); 67 Pa. Code § 171.49 (relating to defrosters); 67 Pa. Code § 171.50 (relating to doors and emergency exits); 67 Pa. Code § 171.51 (relating to fire extinguisher); 67 Pa. Code § 171.57 (relating to insulation); 67 Pa. Code § 171.58 (relating to interior); 67 Pa. Code § 171.59 (relating to lamps and signals); 67 Pa. Code § 171.60 (relating to metal treatment); 67 Pa. Code § 171.68 (relating to seat belts); 67 Pa. Code § 171.69 (relating to seats and crash barriers); 67 Pa. Code § 171.75 (relating to undercoating); 67 Pa. Code § 171.78 (relating to windows); 67 Pa. Code § 171.81 (relating to wiring); 67 Pa. Code § 171.82 (relating to backup alarm); 67 Pa. Code § 171.93 (relating to securement devices and safety restraints); 67 Pa. Code § 171.99 (relating to restraining devices); 67 Pa. Code § 171.106 (relating to power lift uprights, barriers and chair or elevator-type lifts through the floor); 67 Pa. Code § 171.122 (relating to fire extinguisher); and 67 Pa. Code § 171.132 (relating to fire extinguisher).

**APPENDIX B
NATIONAL SCHOOL BUS YELLOW**

The color known as National School Bus Yellow was designated as such by the 1939 National Conference on School Bus Standards. The National Bureau of Standards of the United States Department of Commerce assisted in developing this color and its colorimetric specifications, as follows:

C.I.E. Chromaticity Coordinates		Daylight Reflectance Y (%)			Dominant Wavelength (in millicrons)			Excitation Purity P (%)		
x	y	max.	std.	min.	max.	std.	min.	max.	std.	min.
.5211	.4549	—	41.	40.	584.5	583.5	582.5	—	93.7	89.0

At the 1980 Conference the colors in use were reviewed. A color standard was selected, slightly different from the above, and specific tolerances were chosen. These tolerances will insure a continuity of appearance from school bus to school bus, and within the same school bus when different elements are finished or refinished at different times. Specification for the Standard Color, with light and dark tolerances (Upper and Low Reflectances) are shown below in tabular form.

SPECIFICATION FOR STANDARD COLOR

For Source C

CIE Chromaticity Coordinates		Reflectance Y (%)	Reflectance tolerances	
x	y		Upper	Lower
.5089	.4408	40.14%	41.77%	38.45%

Source

The provisions of this Appendix B adopted August 19, 1983, effective August 20, 1983, 13 Pa.B. 2561; readopted December 4, 1987, effective December 5, 1987, 17 Pa.B. 5052. Immediately preceding text appears at serial page (83769).

Cross References

This appendix cited in 67 Pa. Code § 171.18 (relating to color); 67 Pa. Code § 171.47 (relating to color); 67 Pa. Code § 171.55 (relating to identification); 67 Pa. Code § 171.124 (relating to identification); and 67 Pa. Code § 171.134 (relating to identification).

[Next page is 173-1.]

171-80

(311766) No. 369 Aug. 05

Copyright © 2005 Commonwealth of Pennsylvania